



AquaLink® RS Serial Adapter

Generic and PHASTLink

Owners & Installation Manual



Table of Contents

1	<i>Description</i>	1
2	<i>AquaLink RS Serial Adapter Unit Installation</i>	1
3	<i>RS Serial Adapter Host Protocol</i>	5
3.1	EIA-232 Configuration	5
3.2	Interface Signals Supported	5
3.3	Minimal Interface Connections	5
3.4	General Configuration	5
3.4.1	Data Framing.....	5
3.4.2	Baud Rates.....	6
3.5	Flow Control	6
3.5.1	Internal Data Buffering	6
3.6	RS Serial Adapter Reset via EIA-232	6
3.7	General Command-Response Formats	7
3.7.1	Query Commands	8
3.7.2	Query/Set Commands	9
3.7.3	Query/Toggle/Set Commands.....	9
3.7.4	Action Commands	11
3.7.5	Command Echo	11
3.8	Command Descriptions	12
3.8.1	RS Serial Adapter Configuration/Control Commands	12
3.8.1.1	ECHO.....	12
3.8.1.2	RSPFMT	12
3.8.1.2.1	Format 0.....	13
3.8.1.2.2	Format 1.....	13
3.8.1.3	RST.....	14
3.8.1.4	VERS.....	14
3.8.1.5	DIAG.....	14
3.8.1.6	S1	15
3.8.1.7	CMDCHR.....	16
3.8.1.8	NRMCHR.....	17
3.8.1.9	ERRCHR.....	17
3.8.1.10	COSMSGs	18
3.8.2	AquaLink System Configuration Status Commands	19
3.8.2.1	MODEL.....	19
3.8.2.2	OPMODE.....	19
3.8.2.3	OPTIONS	19
3.8.2.4	VBAT.....	20
3.8.2.5	LEDS.....	20
3.8.3	AquaLink System Pump Commands	21
3.8.3.1	PUMPLO.....	21
3.8.3.2	PUMP.....	21
3.8.3.3	CLEANR	22
3.8.3.4	WFALL.....	22
3.8.3.5	SPA.....	22
3.8.4	AquaLink System Temperature Commands	23

Table of Contents

3.8.4.1	POOLHT	23
3.8.4.2	POOLHT2	23
3.8.4.3	SPAHT	24
3.8.4.4	SOLHT	24
3.8.4.5	POOLSP	24
3.8.4.6	POOLSP2	24
3.8.4.7	SPASP	25
3.8.4.8	POOLTMP	26
3.8.4.9	SPATMP	26
3.8.4.10	AIRTMP	26
3.8.4.11	SOLTMP	27
3.8.5	AquaLink Auxiliary Control Commands	27
3.8.5.1	Basic Aux Operations	27
3.8.5.2	Auxiliaries at Secondary (Remote) Power Centers	28
3.8.5.3	Extra Aux	28
3.8.5.4	Aux Dimmer Control	29
3.8.5.4.1	Toggle Operations	29
3.8.5.4.2	Stepping Dimmer Level	30
4	Appendices	32
4.1	Serial Adapter Command / Model Matrix	32
4.2	LED Status Data Interpretation	35
4.2.1	LED State Encoding	35
4.2.2	Packing of Status Byte Fields	35
4.3	Error Codes	38
4.4	Using an External Modem with the RS Serial Adapter	40
4.5	Command & Response summary for RS Serial Adapter	42
4.6	PHASTLink Serial Adapter	45
4.6.1	Description	45
4.6.2	Installation Instructions	45

Table of Contents

Figures and Tables

<i>Figure 1: RS Serial Adapter Concept</i>	1
<i>Figure 2: Connections to RS Serial Adapter</i>	3
<i>Figure 3: S1 Switch Settings</i>	4
<i>Figure 4: Wiring Diagram</i>	4
<i>Figure 5: PHASTLink Adapter Concept</i>	45
<i>Table 1: J2 Terminal Block Connections</i>	3
<i>Table 2: EIA-232 Interface Signals</i>	5
<i>Table 3: EIA-232 Processor Reset Configuration Options</i>	6
<i>Table 4: S1 Bit Weights</i>	16
<i>Table 5: Option Switch Bit Weights</i>	19
<i>Table 6: Key to Command Table Cells</i>	32
<i>Table 7: RS Serial Adapter Command/RS Model Matrix</i>	34
<i>Table 8: LED State Encoding</i>	35
<i>Table 9: Packing of LED Status Bytes</i>	35
<i>Table 10: LED Functions for AquaLink RS Models</i>	37
<i>Table 11: Serial Adapter Error Codes</i>	39
<i>Table 12: Modem Configuration Jumpers</i>	40
<i>Table 13: External Modem Signal Connection</i>	41

1. Description

The RS Serial Adapter is an interface that allows a device with an EIA-232 serial port to connect to a Jandy AquaLink® RS system for the purposes of obtaining status and performing limited control operations.

PHASTLink: For connecting to a PHAST system, a specialized version of this Serial Adapter is available. (See Appendix 4.6)

As shown in Figure 1, the microprocessor within the RS Serial Adapter translates simple ASCII commands received over the EIA-232 link into the protocol used by the AquaLink RS Power Center and its connected devices. Conversely, responses from the AquaLink RS Power Center are translated back into a simplified ASCII format and transmitted over the EIA-232 link.

Power for the RS Serial Adapter is provided by the AquaLink RS Power Center on the same cable used for EIA-485 communications.

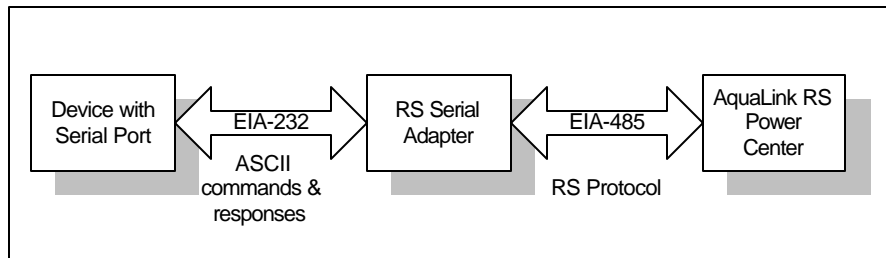

Figure 1: RS Serial Adapter Concept

The RS Serial Adapter supports a wide range of EIA-232 data rates and can be operated with a simple 3-wire interface.

If EIA-232 DTR, DCD or RTS signals are connected between the EIA-232 device and the RS Serial adapter, any one of these signals can be configured, via jumper options, to control the reset of the RS Serial Adapter. A software reset command can also be issued to the RS Serial Adapter over the EIA-232 link.

The RS Serial Adapter also supports connection to a standard external modem using an off-the-shelf cable and serial gender adapter.

2 AquaLink RS Serial Adapter Unit Installation

Operating in conjunction with a Jandy AquaLink RS control system, the RS Serial Adapter allows a computer-controlled automation system to monitor conditions at the pool/spa site. The automation system will also be able to command changes of most pool/spa functions (such as turn on pumps, turn valves, switch the heater or auxiliaries,

and change thermostat settings). Note that the main AquaLink® system will continue to be usable to override the automation system, and will be needed for entering or altering the setup or internal programs stored there. Refer to the AquaLink RS Owner's Manual.

The automation system must be able to communicate through a standard RS-232 serial port, using ASCII characters; it must accept the DB-9S (D-sub. 9 pin, female) connector from the adapter. The AquaLink RS control system must have appropriate firmware installed; revisions marked Rev. HH-232 (or later) can communicate through the adapter. This may be verified with the installer, or by inspecting the label on the PPD ("U2") in the power center, or by pressing & releasing the switch mounted behind the small hole on the side of the AquaLink control panel (first rev. displayed there will be that of the control panel's firmware, the second will be the power center's which is the important one). If Rev. "HH" or older appears, contact Tech. Service at 1 707 776-8200, ext. 260.

Location: this adapter must be used indoors (is not weather-resistant), and should be located near the automation system so that the wires between the RS-232 port and the adapter are fairly short (no more than about 25 feet).

Mounting: determine whether adapter must be fastened to a wall or other surface. If necessary, carefully remove back cover & prepare it for mounting.

Wiring RS-232 port to the adapter:

Follow standard practice for this connection. Three wires (28 AWG or heavier is recommended) are needed for the main functions; a fourth may be used if user wishes to command the adapter to reset *via* DTR, RTS, or DCD. A ribbon cable with DB-9S connector is provided with the adapter.

Wiring Jandy AquaLink® RS control system to the adapter:

Power: Be sure that power to the AquaLink® RS control system is off when making the connection to this adapter. (But don't leave it off for hours, or the battery in the AquaLink will run down; that would cause loss of time & date settings.)

Run 4-wire cable (22 AWG or heavier is recommended) between a device in the AquaLink system and the adapter. That device is typically the indoor control panel, but another may be chosen as long as it is connected using one of the red 4-position terminal bars. Note the wire color codes; these Jandy devices use this standard pattern (see Table 1).

The wires coming from the Serial Adapter may be "doubled up" on the red terminal bar with the four wires coming from the Power Center (see Figure 4). To avoid installing more than two wires in each terminal, order and use a Jandy Multiplex PCB Kit, which includes the Multiplex Board (part #6584). Never put more than two wires into each of the pins of the terminal bar.

Lightning: If the run to the AquaLink RS system is long, and it is in an area prone to lightning storms, a Surge Protection board (part #6585) is recommended.

The connections to the RS Serial Adapter are shown in Figure 2. The RS Serial Adapter enclosure has a removable access cover that provides access to the configuration DIP switch S1, various jumpers, and the terminal block used to connect to the EIA-485/power cable from the Power Center.

Up to two (2) RS Serial Adapters can be connected to the AquaLink RS system. All connections to the Power Center are via the 4-position terminal block (J2), and must be done as shown in Table 1.

The EIA-232 device is connected to the DB-9S connector at the end of the nine-conductor ribbon cable, which is plugged into the RS Serial Adapter PCB at J1. If the connector at J1 is removed for any reason, be sure to replace it with the correct orientation: the cable's marked side (striped) should be up, as viewed in this figure. (That puts its pin 1 up, also.) Jumper headers JP1 through JP4 are used to configure Serial Adapter reset options (described in 3.6). The default jumper configuration is to have a shorting shunt only on JP4, which disables EIA-232 reset options.

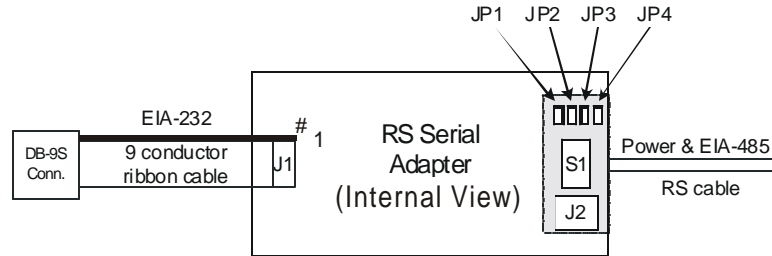

Figure 2: Connections to RS Serial Adapter

Signal Name	Jandy Wire Color	J2 Terminal #	Category 5 Colors
+10VDC	Red	1	Orange + White/Orange
SD+	Black	2	Green
SD-	Yellow	3	White/Green
GND	Green	4	Brown + White/Brown

Table 1: J2 Terminal Block Connections

If (2) complete AquaLink RS systems are present on the site (i.e., there are 2 Main Power Centers), do not attempt to control them with the same RS Serial Adapter. They would not work if their 4-wire cables were connected! However, notice that some versions of the AquaLink RS system include both 1 Main Power Center and 1 (or more) Secondary Power Centers. Those are connected with a common 4-wire cable.

For J2, the table shows the order of wires using Jandy 4-wire cable (part #4278, recommended). If "Category 5" UTP cable is substituted, it may help to double up the power-carrying wires (to terminals 1 and 4) particularly for longer runs; a suggested order is shown as "Category 5 Colors". If the hole is too tight for substituted cable, a hand tool may be used to carefully ream the hold slightly.

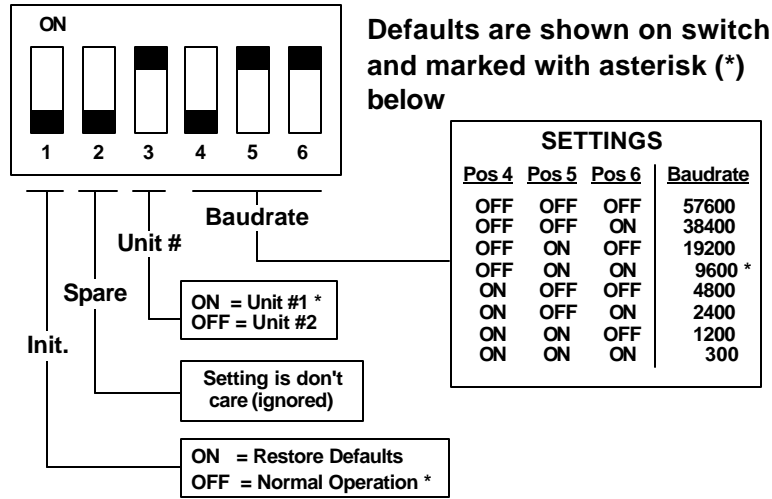

Figure 3: S1 Switch Settings

The RS Serial Adapter unit number is configured by position 3 of S1, as shown in Figure 3. If changing S1 setting, turn power off first (at the Power Center, if possible).

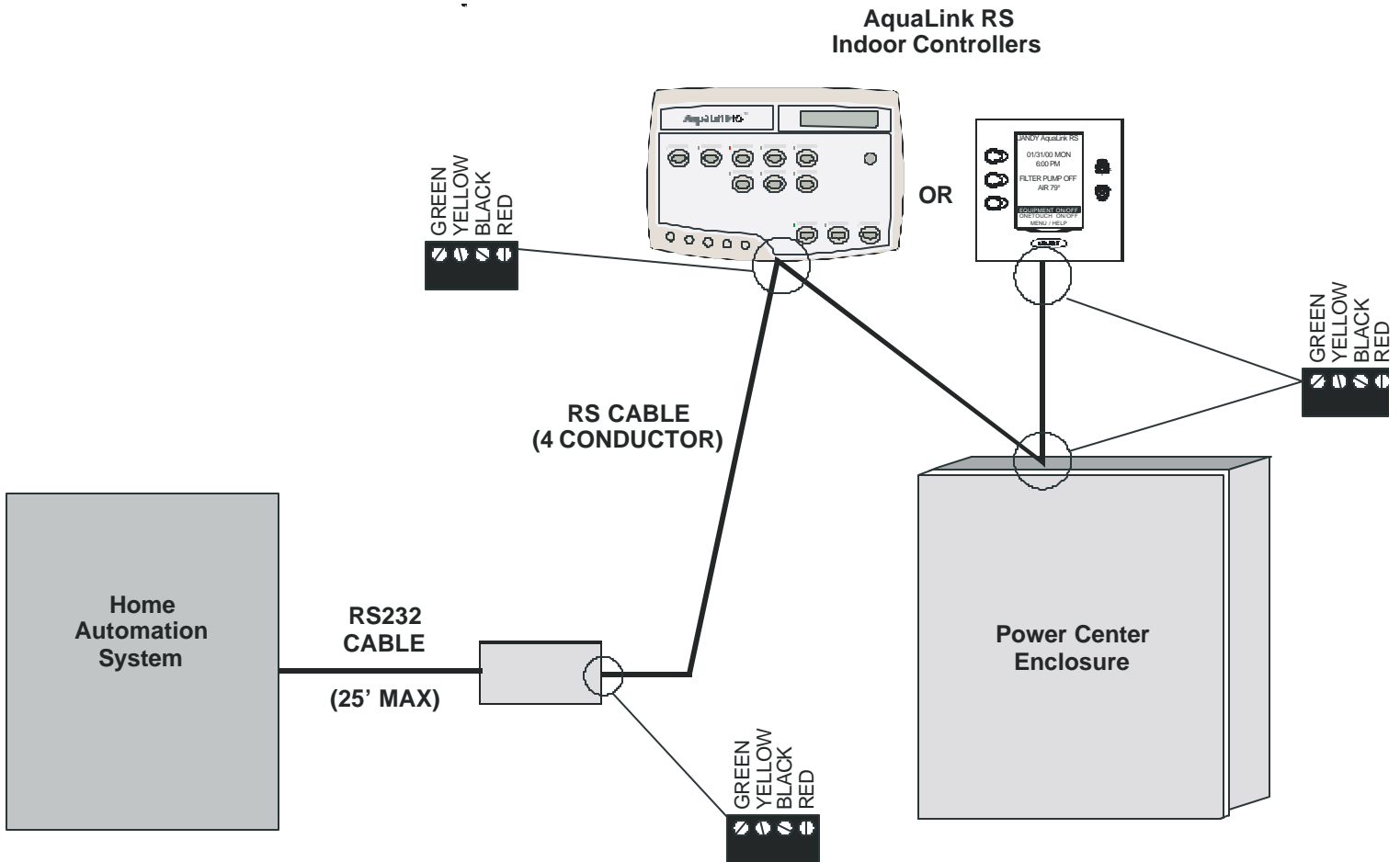

Figure 4: Wiring Diagram

3 RS Serial Adapter Host Protocol

3.1 EIA-232 Configuration

The RS Serial Adapter appears as an EIA-232 Data Communications Equipment (DCE) device. As such, the nine pin DB-9 connector from the RS Serial Adapter can be connected directly (i.e. via a cable wired straight through) to a DTE (Data Terminal Equipment) device such as the standard DB-9 serial port connector of a PC. Basic communications require no special cabling¹.

3.2 Interface Signals Supported

The RS Serial Adapter supports the following EIA-232 signals on its DB-9 connector:

DB9 Pin #	DTE Signal Name	Signal Direction
1	DCD (Data Carrier Detect)	RS Serial Adapter Input ²
2	RXD (Receive Data)	RS Serial Adapter Output
3	TXD (Transmit Data)	RS Serial Adapter Input
4	DTR (Data Terminal Ready)	RS Serial Adapter Input
5	Ground	Input/Output
7	RTS (Request to Send)	RS Serial Adapter Input
8	CTS (Clear to Send)	RS Serial Adapter Output
9	RI (Ring Indicator)	RS Serial Adapter Input ³

Table 2: EIA-232 Interface Signals

Please note that Pin 6 of the DB-9 is unconnected at the RS Serial Adapter. Pins 1 and 9 are unconnected by default, but can be connected by installing jumpers JP5 or JP6 respectively on the Serial Adapter PCB. Pins 1 and 9 would normally not be used unless an external modem is connected to the Serial Adapter. Please refer to section 4.4 for information on using an external modem with the RS Serial Adapter.

3.3 Minimal Interface Connections

The simplest functional connection between an external EIA-232 device and the RS Serial Adapter requires connection of only DB-9 pins 2, 3 and 5.

3.4 General Configuration

3.4.1 Data Framing

The RS Serial Adapter utilizes the following serial data format:

- 8 data bits
- 1 start bit
- 1 stop bit
- no parity

¹ Hosts other than a PC may require using a non straight through cable.

² With Serial Adapter jumper JP5 installed. Otherwise this pin is unconnected.

³ With Serial Adapter jumper JP6 installed. Otherwise this pin is unconnected.

3.4.2 Baud Rates

The RS-232 serial interface operates at any of eight baud rates. The baud rate is selected via three positions of the six-position DIP switch, S1, located under the access cover of the RS Serial Adapter enclosure. Refer to Figure 3 for switch settings.

The switch settings are read by the firmware only during its initialization. The RS Serial Adapter performs initialization following a CPU reset. A CPU reset occurs when:

- power is applied via the EIA-485 interface cable
- the RS Serial Adapter is configured for remote EIA-232 reset and the host momentarily de-asserts the DTR, DCD or RTS (configurable) control line

3.5 Flow Control

The RS Serial Adapter does not currently support hardware or software flow control for the EIA-232 port. Support for these flow control protocols may be added in the future.

3.5.1 Internal Data Buffering

The RS Serial Adapter has a total of 384 bytes of RAM dedicated for the buffering of data to and from the host EIA-232 serial device. This RAM is allocated as follows:

- Data from host to Serial Adapter = 128 bytes
- Data from Serial Adapter to Host = 256 bytes (128 bytes in adapters with revision "A" firmware.)

3.6 RS Serial Adapter Reset via EIA-232

Jumpers JP1 through JP4, located under the access cover of the RS Serial Adapter, can be used to configure the EIA-232 signals DTR or RTS to reset the RS Serial Adapter. Normally these control signals are active (+12V) when the serial interface is operating. The jumpers can be configured to cause a reset of the RS Serial Adapter microprocessor when one of the lines is de-asserted. The reset condition is maintained while the selected control line is in the inactive state.

The valid reset options are shown in Table 3. Please note that all other possible jumper combinations of JP1 through JP4 are invalid and should not be used.

JP1	JP2	JP3	JP4	Effect of this Configuration
Open	open	open	shorted	DCD, DTR, RTS have no effect on reset (default)
Shorted	open	open	open	Generate Reset when DCD not present ⁴
Open	shorted	open	open	Generate Reset when DTR not present
Open	open	shorted	open	Generate Reset when RTS not present

Table 3: EIA-232 Processor Reset Configuration Options

⁴ Jumpers JP5, JP6, and JP7 may be required if you are using an external modem. Refer to section 4.4 for details.

3.7 General Command-Response Formats

All commands to the RS Serial Adapter are comprised of:

- start-of-command character, by default, the pound sign (#)
- the command itself (upper or lower case is acceptable)
- a carriage return (13 decimal, or 0D hexadecimal)

Commands can be entered in upper or lower case, and one or more spaces or tabs are allowed but not required between command elements.

The maximum command line length is 64 characters, including the final carriage return. A carriage return is automatically generated if the command line length exceeds 63 characters.

Normal Responses:

Normal responses to commands start with an ASCII exclamation point (!) and end with a carriage return. A two-digit decimal number after the exclamation point indicates the result status and will always be zero if the command is successful.

Example:

```
!00 SPASP = 89 F CR
```

Error Responses:

Error responses to commands start with an ASCII question mark (?) and end with a carriage return. A two-digit decimal number following the question mark indicates the error status code. Example:

```
?08 SETPT OPERATION FAILED CR
```

Categories of Commands:

RS Serial Adapter commands fall into several categories:

- query commands – commands that return the current status or value of an item. These commands cannot change the value of the item.
- query/set commands – commands that assign a value to a configurable or controllable element of the AquaLink RS system. These commands can also be used to display the current value or status of the item.
- query/toggle/set commands – commands that toggle or directly set the state of a device or item. These commands can also be used to display the current status of an item without changing its state.
- action commands – commands that cause a specific operation to be performed.

The complete command set of the RS Serial Adapter is described in section 3.8. Table 7 (in section 4.1) shows the commands that are supported for each of the Jandy AquaLink RS systems, as well as the command category type for each command.

3.7.1 Query Commands

Query commands are used to return the status or value of some item of interest. Query commands have the following general format:

```
# command ? CR
```

Responses to Query commands can have normal and error formats. The normal response format is:

```
!00 item = value CR
```

The exclamation point and the two zero digits represent normal, successful command status (00 = no error), and the value for the item is displayed, followed by a carriage return.

The error response format is:

```
?NN error_text CR
```

The question mark indicates there was a problem with the command. NN is a two decimal digit error code to help identify the problem. The associated error text is displayed, followed by a carriage return. Error codes are tabulated in section 4.3.

Some examples of valid and invalid commands generating normal and error responses follow.

This sequence shows a command to obtain the current pool temperature. The response indicates that the pool temperature is currently 75 degrees Fahrenheit.

```
Command: #POOLTMP ? CR
Response: !00 POOLTMP = 75 F CR
```

Note: All temperature values are displayed in format 0 as a decimal number followed by a single ASCII space, followed by a "C" or an "F" to denote the units Celsius or Fahrenheit respectively. And as always, the response is terminated by a carriage return.

Here is an example of an invalid command due to a typographical error, and the corresponding error response:

```
Command: #POOPTMP ? CR
Response: ?01 INVALID COMMAND CR
```

3.7.2 Query/Set Commands

Query/Set commands display the current value of an item of interest (like query commands), but also have a form that sets the value of the item before displaying its value. Query/Set commands take the following general forms:

```
# item = value CR      (to set then display value of item)
# item ? CR           (to display current value of item)
```

Numeric values are specified in decimal. On/off values can be specified in several ways:

- On, 1, TRUE, T, YES and Y are all synonymous
- Off, 0, FALSE, F, NO and N are all synonymous

All numeric values must be specified as positive or negative decimal values in the range -32767 to 32768. Most commands further restrict the acceptable range of input values.

Responses to valid query/set commands have the following format:

```
!00 item = value CR
```

Error responses have the following general format:

```
?NN error_text CR
```

By design, this format is the same as that returned by invalid Query (and other) commands.

Some examples of valid and invalid query/set commands generating normal and error responses follow.

This sequence shows a command to obtain the current pool heater setpoint. The response indicates that the pool setpoint is currently 75 degrees Fahrenheit.

```
Command: #POOLSP ? CR
Response: !00 POOLSP = 75 F CR
```

3.7.3 Query/Toggle/Set Commands

Query/Toggle/Set commands can be used to a) toggle the current state/value of an item or device, b) command an item or device to an on or off state, or c) simply display the current state/value of the item or device. Aux devices and pumps and heaters are controlled using query/toggle/set commands.

Query/Toggle/Set commands take the following general forms:

```
Toggle form: # item CR      (toggles the state of the item)
Set form:    # item = state (commands item to state)
Query form:  # item ? CR    (displays the current state of the item)
```

The normal responses to the toggle form of the command are:

!00 item = state CR (displays the new state of the item)

The exclamation point and zero status signify a normal response. An error response to the toggle form of the command looks like:

?NN error_text CR

This error format is consistent with those for the other RS Serial Adapter command types.

An example of the set form of the PUMP command, and a normal response to it are:

#PUMP = 1 CR (Turn on the pump)
!00 PUMP = 1 CR (Pump is on, or will be after a brief delay)

Note that on and off states can be expressed in several ways (case insensitive):

- ON: "1" or "ON" or "YES" or "T" or "TRUE"
- OFF: "0" or "OFF" or "NO" or "F" or "FALSE"

Therefore, some alternative ways of specifying the PUMP command shown in the above example are:

#PUMP = ON CR
#PUMP = Y CR
#PUMP = T CR
#PUMP = True CR
#PUMP = yes CR

Set commands from the Serial Adapter are processed by the Power Center as follows:

1. The current device state is sampled.
2. If the commanded state is not the same as the current device state then:
 - a toggle command is issue to the device
 - the device state is sampled again
3. The last device state sampled is returned to the Serial Adapter.

Important Note:

Because some of the Power Center safety interlocks are not currently decoded by the RS Serial Adapter firmware, it is possible that under some conditions toggle or set commands will not cause the expected change of device state and no error code will be returned. Therefore, software controlling the RS Serial Adapter should not assume that a device control command is successful based on receiving no error response from the RS Serial Adapter.

The query form of a Query/Toggle/Set command, and the resulting response are just like those of other query commands:

Query form: # item ? CR
 Response: !00 item = state CR

Some examples of valid query/toggle/set commands and responses are:

# AUX1 CR	(Toggle state of Aux 1)
!00 AUX1 = 1 CR	(Aux 1 state has been toggled to ON)
# AUX1 ? CR	(Aux 1 state is queried)
!00 AUX1 = 1 CR	(Aux 1 state is ON)
# AUX3 ? CR	(Display state of Aux 3)
!00 AUX3 = 1 CR	(Aux 3 is on)
# AUX3 = OFF CR	(Turn off Aux 3)
!00 AUX3 = 0 CR	(Aux 3 is off)

3.7.4 Action Commands

Action commands cause the RS Serial Adapter to perform specific actions. Action commands have the following format:

command CR

An example action command is:

RST CR

This command resets the RS Serial Adapter. There is no response to this specific command itself, however the RS Serial Adapter will output its usual power up message after it completes its power up sequence.

3.7.5 Command Echo

Command echo is a mode wherein all data sent from the host to the RS Serial Adapter is echoed back, character-for-character. This behavior is desirable, for example, when controlling the RS Serial Adapter manually using a terminal emulation program such as HyperTerminal™ or Procomm™.

Command echo is generally not desirable when a computer controlled device is connected to the RS Serial Adapter, since the echoed command data must be accounted for when processing serial data from the RS Serial Adapter.

The Command echo feature is enabled by default but can be enabled/disabled from the host by means of the Echo command (see below). The state of the echo mode is retained in EEPROM so that it is not lost when the Serial Adapter loses power or is otherwise reset.

3.8 *Command Descriptions*

Command descriptions are grouped according to system function:

- RS Serial Adapter configuration/control commands
- AquaLink system configuration status commands
- AquaLink system pump commands
- AquaLink system temperature commands
- AquaLink system Auxiliary control commands

3.8.1 **RS Serial Adapter Configuration/Control Commands**

3.8.1.1 **ECHO**

This command is used to cause the RS Serial Adapter to echo or to not echo characters it receives over the EIA-232 interface. When echo is enabled, the Serial Adapter echoes an ASCII carriage return character as an ASCII carriage return character followed by an ASCII linefeed character.

Command Example:	#ECHO = ON CR
Command Response:	!00 ECHO = 1 CR
Command Response:	!00 1 CR

Query Example:	#ECHO ? CR
Query Response:	!00 ECHO = 1 CR
Query Response:	!00 1 CR

Default: ON. The echo setting is saved in EEPROM and restored during the Serial Adapter power up sequence.

3.8.1.2 **RSPFMT**

This command sets or displays the current response format used when the RS Serial Adapter responds to commands. The two selectable formats are:

- Format 0 (default): Response is a numeric status code followed by textual message that may include numeric data.
- Format 1: Response is comprised only of numeric or terse alphanumeric fields.

To set response format 0, the following command is used:

Command:	#RSPFMT = 0 CR
Response:	!00 RSPFMT = 0 CR

To set response format 1, the following command is used:

```
Command: #RSPFMT = 1 CR
Response: !00 1 CR
```

3.8.1.2.1 Format 0

Format 0 is usually shown throughout this manual. It is designed to be easily understood by humans when, for example, controlling the RS Serial Adapter from a terminal.

3.8.1.2.2 Format 1

This response format is designed to be interpreted by software (i.e. programs), at the expense of readability for humans. With this format, textual information is replaced by numeric fields. Normal Format 1 responses to valid commands take this form:

```
!SS ddd
```

where SS is the two decimal digit result status (00 = success), and ddd is the data value which is a decimal number or short alphanumeric string.

An example of a Format 1 response to the pool setpoint query command:

```
Command: # POOLSP? CR
Response: !00 75 CR
```

Sometimes special information is encoded in the high bits of Format 1 data values. For example, if the previous example command is issued when the temperature units are Celsius, the sequence becomes:

```
Command: # POOLSP? CR
Response: !00 279 CR
```

In this case, bit 8 (value = 256) denotes Celsius units, and bits 0 through 7 (23 decimal) contain the pool temperature in degrees Celsius. Special encoding, if used, is defined as part of the command description (section 3.8).

If an error is detected, an error response in Format 1 looks like:

```
?NN nn CR
```

where NN is the error code, and nn is a decimal number that may provide additional information.

A program interpreting this error response would have to “know” what the error codes mean. Error code information is provided in section 4.3.

The RSPFMT setting is saved in EEPROM and restored during the Serial Adapter power up sequence.

3.8.1.3 RST

This command resets the RS Serial Adapter. The reset command is entered as follows:

Command: # RST CR

No response is given until the RS Serial Adapter has gone through its normal power up initialization. At that time, the Serial Adapter outputs its normal power up message over the EIA-232 interface. The normal power up message will be similar to:

Jandy Products RS Serial Adapter, Rev Xyy CR

where Xyy indicates the firmware revision level as explained below in section 3.8.1.4.

Important Notes:

- *The values set by the ECHO, RSPFMT, CMDCHR, NRMCHR, and ERRCHR commands are saved in EEPROM and restored automatically during the Serial Adapter power up sequence unless switch S1 position 1 is ON. If switch S1 position 1 is ON when the Serial Adapter is powered up, then default values are used and also saved into the EEPROM.*
- *Resetting the RS Serial Adapter via the RST command causes no adverse effect on the Jandy AquaLink RS Power Center or its remotes.*

3.8.1.4 VERS

This query command displays the version of the RS Serial Adapter firmware.

Command: # VERS? CR

Response: !00 VERS = C01 CR (Response format 0)

Response: !00 C01 CR (Response format 1)

Versions are displayed in the format Xyy, where X is a letter representing the major revision level (A, B, C, etc.) and yy is a two digit decimal number representing the minor revision level. Some example revision strings:

A04 – major revision level A, minor revision level 4

B12 – major revision level B, minor revision level 12

C01 – major revision level C, minor revision level 1

3.8.1.5 DIAG

This action command causes the RS Serial Adapter to execute its internal diagnostics. The diagnostics require approximately 12 seconds to complete. The diagnostic tests performed are, in sequence:

- EPROM checksum test – the stored checksum is compared with calculated value.

- SIO internal loopback test (57600 bps) – all possible data patterns are sent, looped back internally and compared. The UART tested is that which supports the EIA-232 host interface.
- EEPROM read/write test – each location in the EEPROM is checked with two (complementary) data values.

If the EEPROM test fails, an attempt is made to rewrite default values into the device.

Note that the DIAG command places the RS Serial Adapter offline to the Power Center while the tests are performed. Please allow up to ten seconds after diagnostics are completed before attempting to perform additional commands, otherwise a spurious error response may result.

```
Command: #DIAG CR
Response: !00 OK CR          (Response format 0)
Response: !00 0 CR          (Response format 1)
```

Error Response (EPROM checksum error):

```
?14 CHECKSUM ERROR, GOT: XXXXH, EXP: YYYYH CR (Format 0)
where XXXX is the calculated checksum and YYYY was the stored checksum.
```

```
?14 NNN CR (Format 1)
where NNN is the erroneous calculated EPROM checksum, displayed as an
unsigned 16 bit decimal number.
```

Error Response (SIO loopback error):

```
?15 SIO LPBK ERROR CR (Format 0)
?15 0 CR (Format 1)
```

Error Response (EEPROM error):

```
?16 EEPROM R/W TEST ERROR CR (Format 0)
?16 0 CR (Format 1)
```

3.8.1.6 S1

This query command displays the state of the Serial Adapter DIP switch, S1. The switch state is displayed as a decimal number in the range of 0 to 63.

Note that S1 switch position 6 is represented in the least significant bit of the reported value and S1 switch position 1 is represented in the most significant bit of the value (a weight of 32 decimal). Switch positions that are ON show up as '1' bits in the displayed value. Refer to Table 4.

Switch:	Pos 1	Pos 2	Pos 3	Pos 4	Pos 5	Pos 6
Bit Weight:	32	16	8	4	2	1

Table 4: S1 Bit Weights

An example where only S1 positions 3 and 6 are on:

```

Command: #S1? CR
Response: !00 S1 = 9 CR           (Response format 0)
Response: !00 9 CR              (Response format 1)

```

Note that although the switch positions are read and displayed each time the S1 command is issued, the RS Serial Adapter firmware reads and acts upon the switch settings at only these times:

- after any CPU reset (including the normal power-on reset)
- after the DIAG command is issued and upon completion of Serial Loop-back test.

3.8.1.7 CMDCHR

This command sets or displays the character used to start each command line to the RS Serial Adapter. The default value is decimal 35, which corresponds to the ASCII pound (#) character. Values assigned to CMDCHR must fall within the range of 33 (“!”) to 126 (“~”) inclusive.

Examples of the use of this command:

```

Command: #CMDCHR? CR
Response: !00 CMDCHR = 35 CR       (Response format 0)
Response: !00 35 CR              (Response format 1)

Command: #CMDCHR = 96 CR
Response: !00 CMDCHR = 96 CR       (Response format 0)

Command: #CMDCHR? CR
Response: !00 CMDCHR = 96 CR       (Response format 0)

```

The CMDCHR setting is saved in EEPROM and restored during the Serial Adapter power up sequence.

Important Note:

If new values for CMDCHR, NRMCHR, or ERRCHR inadvertently cause EIA-232 communications to be lost, the default values for these characters and ECHO and RSPFMT can be restored by resetting (power cycling) the Serial Adapter with switch S1 position 1 in the ON position (see Figure 3). Once the default values have been restored by this procedure, be sure to reset S1 position 1 to the OFF state.

3.8.1.8 NRMCHR

This command sets or displays the character used by the RS Serial Adapter to begin a normal response message. The default value is decimal 33, which corresponds to the ASCII exclamation point (!) character. Values assigned to NRMCHR must fall within the range of 33 (!) to 126 (~) inclusive.

Examples of using the NRMCHAR command:

```

Command: #NRMCHR? CR
Response: !00 NRMCHR = 33 CR          (Response format 0)
Response: !00 33 CR                  (Response format 1)
Command: #NRMCHR = 37 CR
Response: %00 NRMCHR = 37 CR          (Response format 0)
Response: %00 37 CR                  (Response format 1)

```

The NRMCHR setting is saved in EEPROM and restored during the Serial Adapter power up sequence.

3.8.1.9 ERRCHR

This command sets or displays the character used by the RS Serial Adapter to begin an error response message. The default value is decimal 63, which corresponds to the ASCII question mark character. Values assigned to ERRCHR must fall within the range of 33 (!) to 126 (~) inclusive.

Examples of using the ERRCHAR command:

```

Command: #ERRCHR? CR
Response: !00 ERRCHR = 63 CR          (Response format 0)
Response: !00 63 CR                  (Response format 1)

Command: #ERRCHR = 42 CR
Response: !00 ERRCHR = 42 CR          (Response format 0)
Response: !00 42 CR                  (Response format 1)

Command: #PICKLE CR                   (Not a valid command)
Response: *01 INVALID COMMAND CR      (Response format 0)
Response: *01 00 CR                   (Response format 1)

```

The ERRCHR setting is saved in EEPROM and restored during the Serial Adapter power up sequence.

3.8.1.10 COSMSGS

This command sets or displays the status of the reporting function called “Change Of State Messages”. When this function is enabled (COSMSGS=1), the Serial Adapter sends messages to the EIA-232 port whenever devices in the AquaLink system change state. This means that an external system can be informed of those changes automatically, without having to poll the AquaLink system periodically.

By default, this function is disabled. If wanted, it must be activated after the complete systems are connected and online (and must be re-activated if the AquaLink system is reset, such as by return of power after an interruption). Note that if such reset occurs, the Serial Adapter sends a text string “Jandy Products RS Serial Adapter, Rev [Lnn]” where Lnn=a letter + 2 numbers that indicate the Serial Adapter’s firmware version. This function is not present in firmware older than “B00”.

Changes of device state which can be reported by this function include turning on or off a pump or auxiliary, either by a person pressing a button on the AquaLink system or by reaching the time when an event is programmed into that system. Temperature changes can also be reported, as will changes of the battery voltage (possibly even if the change is too small to be noticed in the “!00 VBAT=nn” report, which has limited resolution). Auxiliary devices are known by their aux.#, regardless of any label that may have been assigned.

Examples:

Command: #COSMSGS = 1 CR (Activate change of state reporting)
 Response: !00 COSMSGS = 1 CR (Response Format 0)

(Note: Response Format 1 is not recommended with this reporting function, because the automatically generated messages would not be specific enough.)

The following shows automatic reports seen as pool water heated up (with set point = 80 degrees).

!00 POOLTMP = 79 F
 !00 VBAT = 921 (Voltage on battery reported as 921/100 = volts.)
 !00 POOLTMP = 80 F (Set point was reached, so heater shut off.)
 !00 VBAT = 921 (No report here about heater, as it is still enabled.)
 !00 POOLTMP = 79 F
 !00 VBAT = 919
 !00 PUMP = 0 (Button on power center was pressed, causing pump to stop.)
 !00 OPMODE = SERVICE (AquaLink system is now in service mode, because of that button press.)
 !00 AUX2 = 1 (Auxiliary #2 came on.)

3.8.2 AquaLink System Configuration Status Commands

3.8.2.1 MODEL

This query command displays the model number of the AquaLink RS system.

An example of its use:

```
Command: # MODEL ? CR
Response: !00 MODEL = 6520 CR          (Response format 0)
Response: !00 6520 CR                 (Response format 1)
```

3.8.2.2 OPMODE

This query command displays the operational mode of the AquaLink RS system. The operational mode is controlled by a button at the Power Center and can be Auto, Service, or Timeout. Examples of OPMODE query command use:

```
Command: # OPMODE ? CR
Response: !00 OPMODE = AUTO CR        (Response format 0)
Response: !00 0 CR                    (Response format 1)
```

```
Command: # OPMODE ? CR
Response: !00 OPMODE = SERVICE CR     (Response format 0)
Response: !00 1 CR                    (Response format 1)
```

```
Command: # OPMODE ? CR
Response: !00 OPMODE = TIMEOUT CR    (Response format 0)
Response: !00 2 CR                    (Response format 1)
```

Note that when using response format 1, the values displayed map to the operating modes as follows: 0 = Auto mode, 1 = Service mode, and 2 = Timeout mode.

3.8.2.3 OPTIONS

This query command displays the state of the Power Center options DIP switch. The options switch state is displayed as a decimal number in the range of 0 to 255.

```
Command: # OPTIONS? CR
Response: !00 OPTIONS = 17 CR         (Response format 0)
Response: !00 17 CR                   (Response format 1)
```

Note that DIP switch position 1 is represented in the least significant bit of the reported value, and DIP switch position 8 is represented in the most significant bit of the value (a weight of 128 decimal) as shown in Table 5. A switch that is ON shows up as a '1' bit in the reported value.

Switch:	Pos 8	Pos 7	Pos 6	Pos 5	Pos 4	Pos 3	Pos 2	Pos 1
Bit Weight:	128	64	32	16	8	4	2	1

Table 5: Option Switch Bit Weights

The option switch settings are explained in the AquaLink RS Installation Manual.

Suggestion: A well engineered software program could use the MODEL and OPTIONS query commands to determine which RS Serial Adapter commands are valid for the system to which it is connected. Refer to section 4.1.

3.8.2.4 VBAT

This query command displays the voltage of the 9V backup battery at the Power Center. The battery voltage is displayed in hundredths of volts and is flagged if the Power Center considers the battery voltage too low. A low battery condition indicates that the battery should be replaced to ensure reliable backup operation.

In the first example, the battery voltage reads 8.97 volts and is not flagged as low:

```
Command: #VBAT? CR
Response: !00 VBAT = 897 CR           (Response format 0)
Response: !00 897 CR                 (Response format 1)
```

In the next example, the battery voltage is reported to be 6.11 volts and it is flagged as a low voltage (indicated by the word "LOW" after the voltage):

```
Command: #VBAT? CR
Response: !00 VBAT = 611 LOW CR       (Response format 0)
Response: !00 2659 CR                 (Response format 1)
```

Note that in response format 1, the low battery condition flag is encoded as a value of 2048 (bit 11) added to the battery value. Therefore the value reported in response format 1 must be interpreted as follows to obtain the actual battery voltage:

```
if value < 2048 then VBAT = (value / 100)      (Voltage OK)
otherwise VBAT = (value - 2048) / 100          (Voltage LOW)
```

Note also that voltages reported by the VBAT command are accurate to approximately plus or minus 2 percent (2%).

3.8.2.5 LEDS

This query command displays LED status data that are sent periodically to the RS Control Panels.

When response format 0 is used, forty bits (5 bytes) of LED status data are displayed. The displayed values represent the data for byte 1 through byte 5 of the LED status data. With the additional information provided in section 4.2, it is possible to decode intermediate states of devices. An example:

```
Command: #LEDS? CR
Response: !00 LEDS = 32 1 0 16 0 CR   (Response format 0)
```

If response format 1 is used, only two (2) bytes of LED status are displayed, as explained below. Here is the same LED data as was shown for the previous example, except that response format 1 is active.

Command: #LEDS? CR

Response: !00 8193 CR (Response format 1)

Response format 1 displays only two bytes of LED status combined into a single 16 bit value, displayed in decimal. The displayed value is calculated as follows:

$$\text{value} = (\text{data}_{\text{BYTE1}} * 256) + \text{data}_{\text{BYTE2}}$$

3.8.3 AquaLink System Pump Commands

All of the pump commands are query/toggle/set commands.

3.8.3.1 PUMPLO

This command controls the low speed of the filter pump, if the low speed option is configured at the Power Center (options switch position 2, weight = 2).

Command: # PUMPLO CR

Response: !00 PUMPLO = 1 CR (Response format 0)

Response: !00 1 CR (Response format 1)

If the low speed pump option is not configured at the Power Center when the command is issued, the following sequence occurs:

Command: # PUMPLO CR

Response: ?23 OPTION SWITCH NOT SET CR (Response format 0)

Response: ?23 0 CR (Response format 1)

If the pump is not already running at high speed, the following sequence occurs:

Command: # PUMPLO CR

Response: ?26 PUMP HIGH NOT ON CR (rspfmt 0), or ?26 0 CR (fmt 1)

3.8.3.2 PUMP

This command controls and/or displays the state of the filter pump.

Command: # PUMP CR

Response: !00 PUMP = 1 CR (rspfmt 0), or !00 1 CR (fmt 1)

3.8.3.3 CLEANR

This command controls/queries the state of the pool cleaner, if the pool cleaner/Aux 1 option is configured at the Power Center (options switch position 1, weight = 1).

Command: # CLEANR CR
 Response: !00 CLEANR = ON CR (fmt 0) , or !00 1 CR (fmt 1)

If the cleaner/Aux 1 option is not configured at the Power Center when the command is issued, the following sequence occurs:

Command: # CLEANR CR
 Response: ?23 OPTION SWITCH NOT SET CR, or ?23 0 CR (fmt 1)

3.8.3.4 WFALL

This command controls and queries the state of the Spa Spillover (waterfall), if the Spa Spillover/Aux 3 option is configured at the Power Center (options switch position 3, weight = 4).

Command: # WFALL = ON CR
 Response: !00 WFALL = 1 CR (Response format 0)
 Response: !00 1 CR (Response format 1)

If the Spa Spillover/Aux 3 option is not configured at the Power Center when the command is issued, the following sequence occurs:

Command: # WFALL CR
 Response: ?23 OPTION SWITCH NOT SET CR (Response format 0)
 Response: ?23 0 CR (Response format 1)

3.8.3.5 SPA

This command controls and queries the state of the spa mode.

Command: # SPA = ON CR (set SPA on)
 Response: !00 SPA = 1 CR (Response format 0)
 Response: !00 1 CR (Response format 1)

Notice that starting or stopping the spa mode can change the status of more than 1 device (such as a pump, valves, pool cleaner, and even a heater).

3.8.4 AquaLink System Temperature Commands

The current temperature units can be determined directly by the UNITS command:

```
Command: #UNITS ? CR
Response: !00 UNITS = F CR (units are Fahrenheit)
or:      !00 UNITS = C CR (units are Celsius)
```

See the owner's manual for the AquaLink RS system, for a description of heater functions. Generally, a command like POOLHT = ON simply enables the heater. It will not actually start heating unless that pump is running and the water temperature is cooler than the set point (thermostat) for that body of water.

Note that all temperature values reported using response format 1 are encoded as follows:

- If the reported value is > 255 then the units are Celsius and temperature (in degrees Celsius) is equal to the reported value minus 256.
- Otherwise the temperature units are Fahrenheit and the reported value is used directly.

3.8.4.1 POOLHT

This query/toggle/set command controls and queries the state of the pool heater.

```
Command: # POOLHT = ON CR (Turn on heater)
Response: !00 POOLHT = 1 CR (Response format 0)
Response: !00 1 CR (Response format 1)

Command: # POOLHT CR (Toggle it off)
Response: !00 POOLHT = 0 CR (Response format 0)
Response: !00 0 CR (Response format 1)
```

3.8.4.2 POOLHT2

The query/toggle/set command controls and queries whether the water heater is enabled to heat to the second thermostat setting. This setting applies only to AquaLink models called "Pool Only/Spa Only" (such as #6688). Refer to the AquaLink owner's manual, where this setting is called "TEMP2". See below for the command "POOLSP2" that can display or adjust this temperature setting.

```
Command: #POOLHT2 = OFF CR (Turn off this heater setting)
Response: !00 POOLHT2 = 0 CR (Acknowledged, in response format 0)
```

3.8.4.3 SPAHT

This query/toggle/set command controls and queries the state of the spa heater.

Command: # SPAHT = ON CR (Turn on Spa heater)
 Response: !00 SPAHT = 1 CR (Response format 0)
 Response: !00 1 CR (Response format 1)

3.8.4.4 SOLHT

This query/toggle/set command controls and queries the state of the solar heater. (If no solar temp. sensor is connected, an error message is generated.)

Command: # SOLHT = ON CR (Turn on Solar heater)
 Response: !00 SOLHT = 1 CR (Response format 0)
 Response: !00 1 CR (Response format 1)

3.8.4.5 POOLSP

This command sets or displays the pool heater setpoint. An example of a successful command sequence is:

Command: # POOLSP = 78 CR
 Response: !00 POOLSP = 78 F CR (Response format 0)
 Response: !00 78 CR (Response format 1)

When changing a setpoint, no units are specified in the command line; temperatures are interpreted by the Power Center as being in the current temperature units.

An example of an unsuccessful setpoint change is:

Command: # POOLSP = 110 CR
 Response: ?08 SETPT OPERATION FAILED CR (Response format 0)
 Response: ?08 0 CR (Response format 1)

3.8.4.6 POOLSP2

This command sets or displays the pool heater setpoint #2.

Command: # POOLSP2 = 75 CR
 Response: !00 POOLSP2 = 75 F CR (Response format 0)
 Response: !00 75 CR (Response format 1)

Temperatures are interpreted in the current temperature units. Error responses assume the same formats as shown for POOLSP. POOLSP2 applies to models that have 2 thermostat settings for the one body of water. (Example: an AquaLink RS 16 Pool Only (catalog part #7261), that shows through the serial adapter as MODEL 7215 which is

the number displayed on the AquaLink control panel). It does not apply to models that control both a pool and a spa setting.

Attempts to change a nonexistent setpoint will lead to an error response.

Example (assuming model = 7215):

```
Command: #SPASP+ CR
Response: ?01 INVALID COMMAND CR      (No "Spa Heater" on this model.)
```

POOLSP>POOLSP2

For models with 2 pool thermostat setpoints, notice that the first one should be set higher than the second. Here are the default settings:

```
Command: #poolsp?
Response: !00 POOLSP = 80 F
Command: #poolsp2?
Response: !00 POOLSP2 = 60 F
```

3.8.4.7 SPASP

This command sets or displays the spa heater setpoint.

```
Command: # SPASP = 94 CR
Response: !00 SPASP = 94 F CR      (Response format 0)
Response: !00 94 CR                (Response format 1)
```

Temperatures are interpreted in the current temperature units. Error responses assume the same format as shown for POOLSP.

Incremental Change of set point.

A heater's setpoint can be changed one degree at a time by using a + or – after its name. Example (assuming pool thermostat was set to 80 degrees Fahrenheit):

```
Command: #POOLSP+ CR
Response: !00 POOLSP= 81 F CR
```

This incremental change can be applied to any set point that is present, and can be repeated.

If the 1-degree change would put the heater setting beyond its limits, the command will not take effect: in that case, the response would show an error.

Example (assuming spa thermostat was set to 104 degrees Fahrenheit):

```
Command: #SPASP+ CR
Response: ?08 SETPT OPERATION FAILED CR
```

Command: #SPASP-CR
 Response: !00 SPASP=103 F CR

3.8.4.8 POOLTMP

This command displays the current pool water temperature.

Command: # POOLTMP ? CR
 Response: !00 POOLTMP = 72 F CR (Response format 0)
 Response: !00 72 CR (Response format 1)

Note that the water temperature is not read if the pump is off, and that there is a delay between the turn on of the pump and the availability of the temperature reading. If the water temperature measurement is not available, the response will be returned as follows:

?18 POOL TEMP VALUE IS UNAVAILABLE CR

(For older versions, the words "POOL TEMP" are not used in the above context.)

3.8.4.9 SPATMP

This command displays the current Spa water temperature.

Command: # SPATMP ? CR
 Response: !00 SPATMP = 72 F CR (Response format 0)
 Response: !00 72 CR (Response format 1)

Note that there is a delay between the turn on of spa mode and the availability of its temperature reading. If the spa water temperature measurement is not available, the response will be returned as follows:

?18 VALUE IS UNAVAILABLE CR

3.8.4.10 AIRTMP

This command displays the current air temperature.

Command: # AIRTMP ? CR
 Response: !00 AIRTMP = 85 F CR (Response format 0)
 Response: !00 85 CR (Response format 1)

If the air temperature measurement is not available, an error message is sent, such as:

?19 AIR TEMP SENSOR IS OPEN CR

3.8.4.11 SOLTMP

This command displays the current solar heater water temperature. This temperature value can be displayed even if the pump is off.

This command is not available with Dual Equipment models because the temperature sensor channel is used instead for Spa water temperature.

```
Command: # SOLTMP ? CR
Response: !00 SOLTMP = 72 F CR    (Response format 0)
Response: !00 72 CR              (Response format 1)
```

If the solar water temperature not available, the response is an error message such as:

```
?18 VALUE IS UNAVAILABLE CR
```

3.8.5 AquaLink Auxiliary Control Commands

3.8.5.1 Basic Aux Operations

This query/toggle/set command controls an Aux output and can also display the current state of an Aux output. Auxiliary outputs assigned to dimmers can also be fully controlled as described below.

The toggle form of the AUX command is:

```
Command: # AUXn CR                (n is 1 to 31 max., depending on model)
Response: !00 AUXn = 1 CR         (Response format 0)
Response: !00 1 CR               (Response format 1)
```

The set form of the AUX command is:

```
Command: # AUXn = state CR       (n is 1 to 31 max., as noted above)
Response: !00 AUXn = s CR        (Response format 0, s = 0 or 1)
Response: !00 s CR              (Response format 1, s = 0 or 1)
```

Note that *state* can be any of "1" or "ON" or "T" or "TRUE" or "Y" or "YES" for on, and similarly, it can be any of "0" or "OFF" or "F" or "FALSE" or "N" or "NO" for off.

The query form of this command is:

```
Command: # AUXn? CR              (n is 1 to 31 max., as above)
Response: !00 AUXn = 1 CR        (Response format 0)
Response: !00 1 CR              (Response format 1)
```

Commands using Aux numbers 1 to 3 are invalid when option switches 1 to 3 respectively are set at the Power Center. The Serial Adapter returns an error code in such cases. For example, if option switch 1 is set to enable the Cleaner (CLEANR command) function, and control of Aux 1 is attempted:

Command: # AUX1 CR (Try to toggle Aux 1)
 Response: ?24 OPTION SWITCH IS SET CR (Response format 0)
 Response: ?24 0 CR (Response format 1)

3.8.5.2 Auxiliaries at Secondary (Remote) Power Centers

If the AquaLink system includes more than 1 power center (such as an AquaLink RS16 or RS2/14), its additional auxiliaries are seen slightly differently through the serial adapter. The serial adapter addresses all auxiliaries in simple numerical order, regardless of which power center they are in (and regardless of any labels assigned to them). Other devices in the AquaLink system, such as an indoor control panel, may refer to an auxiliary with a letter and number combination.

Example with RS16: The first aux. in the Secondary Power Center is called “B1” there, while the serial adapter addresses the same device as Aux8.

3.8.5.3 Extra Aux

If no solar function is present (i.e., no solar temperature sensor) in the AquaLink system, then an additional auxiliary can be controlled in its place. (That uses the “Solar Pump” socket on the Power Center.) This can be treated like other auxiliaries, using the AUXX command.

Example:

Command: #AUXX = ON CR
 Response: !00 AUXX = 1 CR

This additional auxiliary can control a dimmer module, but that must be correctly setup. (See the next section for details about the dimming functions.)

Example:

Command: #AUXX + CR (Attempt to set up brightness)
 Response: ?21 AUX NOT ASSIGNED TO DIMMER CR

If the solar function (sensor) is present, then an attempt to use the AUXX command leads to an error message like the following:

Command: #AUXX = ON CR
 Response: ?01 INVALID COMMAND

[Note: Simply adding the solar sensor is not quite enough. The AquaLink responds to that change, but the serial adapter does not recognize it unless there is a reset from either cycling of the line power or pressing of the RESET button at the power center.]

3.8.5.4 Aux Dimmer Control

Aux outputs that have been assigned to dimmers can be fully controlled by the RS Serial Adapter. Note that dimmer hardware modules must also be installed in the Power Center before dimmer control can be performed.

Aux dimmer control via the Serial Adapter operates analogously to dimmer control via the RS Control Panel:

- Auxiliary outputs with dimmers are set or toggled on/off just like other Auxiliaries
- When an Aux with dimmer is turned on, the dimmer level is restored to its previous level and the dimmer level is displayed
- Dimmer level can only be adjusted when the output is on
- Dimmer levels can be adjusted up or down in 25% steps

3.8.5.4.1 Toggle Operations

Turning on an Aux assigned to a dimmer (a toggle to on):

Command:	# AUXn CR	(n is 1 to 31 max., depending on model)
Response:	!00 AUXn = 1 50% CR	(Response format 0)
Response:	!00 178 CR	(Response format 1)

This example shows the dimmer at a 50% level when turned on. The dimmer state/level is encoded in response format 1 as follows:

- Dimmer off: value = 0
- Dimmer on: value = 128 + dimmer level (%)

Therefore, possible encoded values for dimmer levels are:

- 0 = Off
- 153 = On at 25% level
- 178 = On at 50% level
- 203 = On at 75% level
- 228 = On at 100% level

Thus, in the example shown above, the value “178” represents a dimmer ON at 50%. This same encoding is applied to Aux dimmer status query responses when format 1 is used.

Turning off an Aux assigned to a dimmer (a toggle to off):

Command:	# AUXn CR	(n is 1 to 31 max., as above)
Response:	!00 AUXn = 0 CR	(Response format 0)
Response:	!00 0 CR	(Response format 1)

3.8.5.4.2 Stepping Dimmer Level

The level of a dimmer that is on can be stepped up or down. Stepping causes the level to change in 25% steps, except that the 0% level is skipped.

Step Up Example

The following example shows a dimmer that's initially on at the 25% level. It's queried, then stepped through 50%, 75%, 100% levels, then finally stepped back to the 25% level. Responses are shown in both formats for clarity.

Command:	#AUXn? CR	(Query the dimmer)
Response:	!00 AUXn = 1 25% CR	(Response format 0)
Response:	!00 153 CR	(Response format 1)
Command:	# AUXn + CR	(Step dimmer level up)
Response:	!00 AUXn = 1 50% CR	(Response format 0)
Response:	!00 178 CR	(Response format 1)
Command:	# AUXn + CR	(Step dimmer level up)
Response:	!00 AUXn = 1 75% CR	(Response format 0)
Response:	!00 203 CR	(Response format 1)
Command:	# AUXn + CR	(Step dimmer level up)
Response:	!00 AUXn = 1 100% CR	(Response format 0)
Response:	!00 228 CR	(Response format 1)
Command:	# AUXn + CR	(Step dimmer level up)
Response:	!00 AUXn = 1 25% CR	(Response format 0)
Response:	!00 153 CR	(Response format 1)

Attempting to step a dimmer that is off returns an error:

Command:	#AUXn? CR	(Query the dimmer)
Response:	!00 AUXn = 0 CR	(Response format 0)
Response:	!00 0 CR	(Response format 1)
Command:	# AUXn + CR	(Step dimmer level up)
Response:	?22 AUX OFF: DIMMER CTL IGNORED CR	(Response format 0)
Response:	?22 0 CR	(Response format 1)

Step Down Example

The following example shows a dimmer that's initially on at the 25% level. It's queried, then stepped down through 100%, 75%, 50% levels, then finally stepped back to the 25% level. Responses are shown in both formats for clarity.

Command:	#AUXn? CR	(Query the dimmer)
Response:	!00 AUXn = 1 25% CR	(Response format 0)
Response:	!00 153 CR	(Response format 1)
Command:	# AUXn - CR	(Step dimmer level down)
Response:	!00 AUXn = 1 100% CR	(Response format 0)
Response:	!00 228 CR	(Response format 1)
Command:	# AUXn - CR	(Step dimmer level down)
Response:	!00 AUXn = 1 75% CR	(Response format 0)
Response:	!00 203 CR	(Response format 1)
Command:	# AUXn - CR	(Step dimmer level down)
Response:	!00 AUXn = 1 50% CR	(Response format 0)
Response:	!00 178 CR	(Response format 1)
Command:	# AUXn - CR	(Step dimmer level down)
Response:	!00 AUXn = 1 25% CR	(Response format 0)
Response:	!00 153 CR	(Response format 1)

4 Appendices

4.1 Serial Adapter Command / Model Matrix

Table 7 indicates which commands are supported for the various Jandy AquaLink RS Models. Footnotes also appear below in the matrix to flag special cases and/or other pertinent information.

Cell	Meaning
A	Action command
Q/T/S	Supported for toggling the item, setting the item on or off, and for querying its status. This is a query/toggle/set command.
Q	Command can be used only to return status (query command).
Q/S	Command allows setting and querying the value of an item.
	Indicates the command is not valid for the particular model number. An attempt to use it will cause an error response to be returned by the RS Serial Adapter.

Table 6: Key to Command Table Cells

RS Serial Adapter Manual

Name →	RS-8 combo	RS-6 combo	RS-4 combo	RS-8 PS	RS-6 PS	RS-4 PS	RS-2/6 dual eq.	RS-8 combo	RS-8 PS	RS-12 combo	RS-16 combo	RS-12 PS	RS-16 PS	RS-2/10 dual eq.	RS-2/14 dual eq.
Model No. → ↓ Commands	6520	6521	6522	6523	6524	6525	6526	6536*	6537*	7201	7202	7214	7215	7216	7217
#AIRTMP	Q	Q	Q	Q	Q	Q	Q	Q	Q	Q	Q	Q	Q	Q	Q
#AUX1	Q/T/S ¹	Q/T/S ¹	Q/T/S ¹	Q/T/S ¹	Q/T/S ¹	Q/T/S ¹	Q/T/S ¹	Q/T/S ¹	Q/T/S ¹	Q/T/S ¹	Q/T/S ¹	Q/T/S ¹	Q/T/S ¹	Q/T/S ¹	Q/T/S ¹
#AUX2	Q/T/S ²	Q/T/S ²	Q/T/S ²	Q/T/S ²	Q/T/S ²	Q/T/S ²	Q/T/S ²	Q/T/S ²	Q/T/S ²	Q/T/S ²	Q/T/S ²	Q/T/S ²	Q/T/S ²	Q/T/S ²	Q/T/S ²
#AUX3	Q/T/S ³	Q/T/S ³	Q/T/S ³	Q/T/S ³	Q/T/S ³	Q/T/S ³	Q/T/S ³	Q/T/S ³	Q/T/S ³	Q/T/S ³	Q/T/S ³	Q/T/S ³	Q/T/S ³	Q/T/S ³	Q/T/S ³
#AUX4	Q/T/S	Q/T/S		Q/T/S	Q/T/S		Q/T/S	Q/T/S	Q/T/S	Q/T/S	Q/T/S	Q/T/S	Q/T/S	Q/T/S	Q/T/S
#AUX5	Q/T/S	Q/T/S		Q/T/S	Q/T/S		Q/T/S	Q/T/S	Q/T/S	Q/T/S	Q/T/S	Q/T/S	Q/T/S	Q/T/S	Q/T/S
#AUX6	Q/T/S			Q/T/S			Q/T/S	Q/T/S	Q/T/S	Q/T/S	Q/T/S	Q/T/S	Q/T/S	Q/T/S	Q/T/S
#AUX7	Q/T/S			Q/T/S				Q/T/S	Q/T/S	Q/T/S	Q/T/S	Q/T/S	Q/T/S	Q/T/S	Q/T/S
#AUX8										Q/T/S	Q/T/S	Q/T/S	Q/T/S	Q/T/S	Q/T/S
#AUX9										Q/T/S	Q/T/S	Q/T/S	Q/T/S	Q/T/S	Q/T/S
#AUX10										Q/T/S	Q/T/S	Q/T/S	Q/T/S	Q/T/S	Q/T/S
#AUX11										Q/T/S	Q/T/S	Q/T/S	Q/T/S		Q/T/S
#AUX12											Q/T/S		Q/T/S		Q/T/S
#AUX13											Q/T/S		Q/T/S		Q/T/S
#AUX14											Q/T/S		Q/T/S		Q/T/S
#AUX15											Q/T/S		Q/T/S		
#CLEANR	Q/T/S ⁴	Q/T/S ⁴	Q/T/S ⁴	Q/T/S ⁴	Q/T/S ⁴	Q/T/S ⁴	Q/T/S ⁴	Q/T/S ⁴	Q/T/S ⁴	Q/T/S ⁴	Q/T/S ⁴	Q/T/S ⁴	Q/T/S ⁴	Q/T/S ⁴	Q/T/S ⁴
#CMDCHR	Q/S	Q/S	Q/S	Q/S	Q/S	Q/S	Q/S	Q/S	Q/S	Q/S	Q/S	Q/S	Q/S	Q/S	Q/S
#DIAG	A	A	A	A	A	A	A	A	A	A	A	A	A	A	A
#ECHO	Q/S	Q/S	Q/S	Q/S	Q/S	Q/S	Q/S	Q/S	Q/S	Q/S	Q/S	Q/S	Q/S	Q/S	Q/S
#ERRCHR	Q/S	Q/S	Q/S	Q/S	Q/S	Q/S	Q/S	Q/S	Q/S	Q/S	Q/S	Q/S	Q/S	Q/S	Q/S
#LEDS	Q	Q	Q	Q	Q	Q	Q	Q	Q	Q	Q	Q	Q	Q	Q
#MODEL	Q	Q	Q	Q	Q	Q	Q	Q	Q	Q	Q	Q	Q	Q	Q
#NRMCHR	Q/S	Q/S	Q/S	Q/S	Q/S	Q/S	Q/S	Q/S	Q/S	Q/S	Q/S	Q/S	Q/S	Q/S	Q/S
#OPMODE	Q	Q	Q	Q	Q	Q	Q	Q	Q	Q	Q	Q	Q	Q	Q
#OPTIONS	Q	Q	Q	Q	Q	Q	Q	Q	Q	Q	Q	Q	Q	Q	Q
#POOLHT	Q/T/S	Q/T/S	Q/T/S	Q/T/S	Q/T/S	Q/T/S	Q/T/S	Q/T/S	Q/T/S	Q/T/S	Q/T/S	Q/T/S	Q/T/S	Q/T/S	Q/T/S
#POOLHT2				Q/T/S	Q/T/S	Q/T/S			Q/T/S			Q/T/S	Q/T/S		

¹ Invalid if Cleaner command (CLEANR) is enabled by setting option switch 1.
² Invalid if Low Speed command (PUMPLO) is enabled by setting option switch 2.
³ Invalid if Spa Spillover command (WFALL) is enabled by setting option switch 3.
⁴ Valid when enabled by setting option switch 1.

RS Serial Adapter Manual

Name →	RS-8 combo	RS-6 combo	RS-4 combo	RS-8 PS	RS-6 PS	RS-4 PS	RS-2/6 dual eq.	RS-8 combo	RS-8 PS	RS-12 combo	RS-16 combo	RS-12 PS	RS-16 PS	RS-2/10 dual eq.	RS-2/14 dual eq.
Model No. → ↓ Commands	6520	6521	6522	6523	6524	6525	6526	6536*	6537*	7201	7202	7214	7215	7216	7217
#POOLSP	Q/S	Q/S	Q/S	Q/S	Q/S	Q/S	Q/S	Q/S	Q/S	Q/S	Q/S	Q/S	Q/S	Q/S	Q/S
#POOLSP2				Q/S	Q/S	Q/S			Q/S			Q/S	Q/S		
#POOLTMP	Q	Q	Q	Q	Q	Q	Q	Q	Q	Q	Q	Q	Q	Q	Q
#PUMP	Q/T/S	Q/T/S	Q/T/S	Q/T/S	Q/T/S	Q/T/S	Q/T/S	Q/T/S	Q/T/S	Q/T/S	Q/T/S	Q/T/S	Q/T/S	Q/T/S	Q/T/S
#PUMPLO	Q/T/S ⁵	Q/T/S ⁵	Q/T/S ⁵	Q/T/S ⁵	Q/T/S ⁵	Q/T/S ⁵	Q/T/S ⁵	Q/T/S ⁵	Q/T/S ⁵	Q/T/S ⁵	Q/T/S ⁵	Q/T/S ⁵	Q/T/S ⁵	Q/T/S ⁵	Q/T/S ⁵
#RSPFMT	Q/S	Q/S	Q/S	Q/S	Q/S	Q/S	Q/S	Q/S	Q/S	Q/S	Q/S	Q/S	Q/S	Q/S	Q/S
#RST	A	A	A	A	A	A	A	A	A	A	A	A	A	A	A
#S1	Q	Q	Q	Q	Q	Q	Q	Q	Q	Q	Q	Q	Q	Q	Q
#SOLHT	Q/T/S	Q/T/S	Q/T/S	Q/T/S	Q/T/S	Q/T/S	Q/T/S	Q/T/S	Q/T/S	Q/T/S	Q/T/S	Q/T/S	Q/T/S	Q/T/S	Q/T/S
#SOLTMP	Q	Q	Q	Q	Q	Q		Q	Q	Q	Q	Q	Q		
#SPA	Q/T/S	Q/T/S	Q/T/S				Q/T/S	Q/T/S		Q/T/S	Q/T/S			Q/T/S	Q/T/S
#SPAHT	Q/T/S	Q/T/S	Q/T/S				Q/T/S	Q/T/S		Q/T/S	Q/T/S			Q/T/S	Q/T/S
#SPASP	Q/S	Q/S	Q/S				Q/S	Q/S		Q/S	Q/S			Q/S	Q/S
#SPATMP	Q	Q	Q				Q	Q		Q	Q			Q	Q
#UNITS	Q	Q	Q	Q	Q	Q	Q	Q	Q	Q	Q	Q	Q	Q	Q
#VBAT	Q	Q	Q	Q	Q	Q	Q	Q	Q	Q	Q	Q	Q	Q	Q
#VERS	Q	Q	Q	Q	Q	Q	Q	Q	Q	Q	Q	Q	Q	Q	Q
#WFALL	Q/T/S ⁶	Q/T/S ⁶	Q/T/S ⁶				Q/T/S ⁶	Q/T/S ⁶		Q/T/S ⁶	Q/T/S ⁶			Q/T/S ⁶	Q/T/S ⁶

Table 7: RS Serial Adapter Command/RS Model Matrix

⁵ Valid when enabled by setting option switch 2.

⁶ Valid when enabled by setting option switch 3.

4.2 LED Status Data Interpretation

This section provides detailed information for interpreting the response data from the Serial Adapter LEDS query command. Recall that the normal response (format 0) to the LEDS query command is:

!00 LEDS = *byte1 byte2 byte3 byte4 byte5 CR*

Table 8 and Table 9 show how LED status is encoded and packed into the five (5) bytes of LED status data. Table 10 shows how the AquaLink RS Power Center drives the LEDs on the Control Panels for each RS model.

4.2.1 LED State Encoding

First, the state of each LED is encoded into a two bit field as shown in Table 8:

Bits		Interpretation of LED state
n+1	n	
0	0	OFF
0	1	ON
1	0	Flash
1	1	Slow Flash

Table 8: LED State Encoding

4.2.2 Packing of Status Byte Fields

The states of four LEDs are packed into each of the five (5) LED status bytes. LED state fields are located as follows within the five bytes of LED status:

LED Byte #	Bits 7, 6		Bits 5, 4		Bits 3, 2		Bits 1, 0	
	128	64	32	16	8	4	2	1
1	LED 4		LED 3		LED 2		LED 1	
2	LED 8		LED 7		LED 6		LED 5	
3	LED 12		LED 11		LED 10		LED 9	
4	LED 16		LED 15		LED 14		LED 13	
5	LED 20		LED 19		LED 18		LED 17	

Table 9: Packing of LED Status Bytes

RS Serial Adapter Manual

Name	RS-8 combo	RS-6 combo	RS-4 combo	RS-8 PS	RS-6 PS	RS-4 PS	RS-2/6 dual eq.	RS-8 combo	RS-8 PS	RS-12 combo	RS-16 combo	RS-12 PS	RS-16 PS	RS-2/10 dual eq.	RS-2/14 dual eq.
Model	6520	6521	6522	6523	6524	6525	6526	6536*	6537*	7201	7202	7214	7215	7216	7217
LED #															
1	Aux 7	Off	Off	Aux 7	Off	Off	Off	Aux 7	Aux 7	Aux 10	Aux 10	Aux 10	Aux 10	Aux 10	Aux 10
2	Off	Off	Off	Off	Off	Off	Off	Off	Off	Aux 4	Aux 4	Aux 4	Aux 4	Aux 4	Aux 4
3	Aux 3	Aux 3	Aux 3	Aux 3	Aux 3	Aux 3	Aux 3	Aux 3	Aux 3	Aux 3	Aux 3	Aux 3	Aux 3	Aux 3	Aux 3
4	Aux 2 ⁷	Aux 2 ⁷	Aux 2 ⁷	Aux 2 ⁷	Aux 2 ⁷	Aux 2 ⁷	Aux 2 ⁷	Aux 2 ⁷	Aux 2 ⁷	Aux 2 ⁷	Aux 2 ⁷	Aux 2 ⁷	Aux 2 ⁷	Aux 2 ⁷	Aux 2 ⁷
5	Aux 1 ⁸	Aux 1 ⁸	Aux 1 ⁸	Aux 1 ⁸	Aux 1 ⁸	Aux 1 ⁸	Aux 1 ⁸	Aux 1 ⁸	Aux 1 ⁸	Aux 1 ⁸	Aux 1 ⁸	Aux 1 ⁸	Aux 1 ⁸	Aux 1 ⁸	Aux 1 ⁸
6	Spa Status ⁹	Spa Status ⁹	Spa Status ⁹	Spa Status ⁹	Spa Status ⁹	Spa Status ⁹	Spa Pump ¹⁰	Spa Status ⁹	Spa Status ⁹	Spa Status ⁹	Spa Status ⁹	Spa Status ⁹	Spa Status ⁹	Spa Pump ¹⁰	Spa Pump ¹⁰
7	Filter Pump Status ¹¹	Filter Pump Status ¹¹	Filter Pump Status ¹¹	Filter Pump Status ¹¹	Filter Pump Status ¹¹	Filter Pump Status ¹¹	Filter Pump Status ¹¹	Filter Pump Status ¹¹	Filter Pump Status ¹¹	Filter Pump Status ¹¹	Filter Pump Status ¹¹	Filter Pump Status ¹¹	Filter Pump Status ¹¹	Filter Pump Status ¹¹	Filter Pump Status ¹¹
8	Aux 5	Aux 5	Off	Aux 5	Aux 5	Off	Aux 5	Aux 5	Aux 5	Aux 8	Aux 8	Aux 8	Aux 8	Aux 8	Aux 8
9	Aux 4	Aux 4	Off	Aux 4	Aux 4	Off	Aux 4	Aux 4	Aux 4	Aux 7	Aux 7	Aux 7	Aux 7	Aux 7	Aux 7
10	Off	Off	Off	Off	Off	Off	Off	Off	Off	Aux 6	Aux 6	Aux 6	Aux 6	Aux 6	Aux 6
11	Off	Off	Off	Off	Off	Off	Off	Off	Off	Aux 5	Aux 5	Aux 5	Aux 5	Aux 5	Aux 5
12	Aux 6	Aux 6	Off	Aux 6	Off	Off	Aux 6	Aux 6	Aux 6	Aux 9	Aux 9	Aux 9	Aux 9	Aux 9	Aux 9
13	Off	Off	Off	Off	Off	Off	Off	Off	Off	Aux 11	Aux 11	Aux 11	Aux 11	Off	Aux 11
14	Off	Off	Off	Off	Off	Off	Off	Off	Off	Off	Off	Off	Off	Off	Off
15	Heater Active ¹²	Heater Active ¹²	Heater Active ¹²	Heater Active ¹²	Heater Active ¹²	Heater Active ¹²	Heater Active ¹²	Heater Active ¹²	Heater Active ¹²	Heater Active ¹²	Heater Active ¹²	Heater Active ¹²	Heater Active ¹²	Heater Active ¹²	Heater Active ¹²
16	Heater Enabled ¹²	Heater Enabled ¹²	Heater Enabled ¹²	Heater Enabled ¹²	Heater Enabled ¹²	Heater Enabled ¹²	Heater Enabled ¹²	Heater Enabled ¹²	Heater Enabled ¹²	Heater Enabled ¹²	Heater Enabled ¹²	Heater Enabled ¹²	Heater Enabled ¹²	Heater Enabled ¹²	Heater Enabled ¹²
17	Heater 2 Enabled ¹³	Heater 2 Active ¹³	Heater 2 Active ¹³	Heater 2 Active ¹³	Heater 2 Active ¹³	Heater 2 Active ¹³	Heater 2 Active ¹³	Heater 2 Active ¹³	Heater 2 Active ¹³	Heater 2 Active ¹³	Heater 2 Active ¹³	Heater 2 Active ¹³	Heater 2 Active ¹³	Heater 2 Active ¹³	Heater 2 Active ¹³

⁷ Indicates Low Pump speed active if option switch 2 is on.

⁸ If cleaner is assigned via option switch 1, an LED flash state indicates switching.

⁹ LED flash state indicates spa mode is switching or cool down mode is active.

¹⁰ LED flash state indicates intermediate/switching state of spa pump.

¹¹ LED flash state indicates the filter pump is waiting for a completion of a delay.

¹² Complete heater status determined by states of LED 15 and LED 16 as follows:

Heater enabled but inactive: LED 15 = Off, LED 16 = On.

Heater enabled and active: LED 15 = On, LED 16 = Off.

RS Serial Adapter Manual

Name	RS-8 combo	RS-6 combo	RS-4 combo	RS-8 PS	RS-6 PS	RS-4 PS	RS-2/6 dual eq.	RS-8 combo	RS-8 PS	RS-12 combo	RS-16 combo	RS-12 PS	RS-16 PS	RS-2/10 dual eq.	RS-2/14 dual eq.
Model	6520	6521	6522	6523	6524	6525	6526	6536*	6537*	7201	7202	7214	7215	7216	7217
LED #															
18	Heater 2 Active ¹³	Heater 2 Enabled ¹³	Heater 2 Enabled ¹³	Heater 2 Enabled ¹³	Heater 2 Enabled ¹³	Heater 2 Enabled ¹³	Heater 2 Enabled ¹³	Heater 2 Enabled ¹³	Heater 2 Enabled ¹³	Heater 2 Enabled ¹³	Heater 2 Enabled ¹³	Heater 2 Enabled ¹³	Heater 2 Enabled ¹³	Heater 2 Enabled ¹³	Heater 2 Enabled ¹³
19	Solar Heater Active ¹⁴	Solar Heater Active ¹⁴	Solar Heater Active ¹⁴	Solar Heater Active ¹⁴	Solar Heater Active ¹⁴	Solar Heater Active ¹⁴	Solar Heater Active ¹⁴	Solar Heater Active ¹⁴	Solar Heater Active ¹⁴	Solar Heater Active ¹⁴	Solar Heater Active ¹⁴	Solar Heater Active ¹⁴	Solar Heater Active ¹⁴	Solar Heater Active ¹⁴	Solar Heater Active ¹⁴
20	Solar Heater Enabled ¹⁴	Solar Heater Enabled ¹⁴	Solar Heater Enabled ¹⁴	Solar Heater Enabled ¹⁴	Solar Heater Enabled ¹⁴	Solar Heater Enabled ¹⁴	Solar Heater Enabled ¹⁴	Solar Heater Enabled ¹⁴	Solar Heater Enabled ¹⁴	Solar Heater Enabled ¹⁴	Solar Heater Enabled ¹⁴	Solar Heater Enabled ¹⁴	Solar Heater Enabled ¹⁴	Solar Heater Enabled ¹⁴	Solar Heater Enabled ¹⁴

Table 10: LED Functions for AquaLink RS Models

¹³ Complete heater status determined by states of LED 17 and LED 18 as follows:

Heater enabled but inactive:
Heater enabled and active:

LED 17 = Off, LED 18 = On;
LED 17 = On, LED 18 = Off.

¹⁴ Complete heater status determined by states of LED 19 and LED 20 as follows:

Heater enabled but inactive:
Heater enabled and active:

LED 19 = Off, LED 20 = On;
LED 19 = On, LED 20 = Off.

4.3 Error Codes

This section shows the possible error codes for the Serial Adapter commands.

	Error Text	Explanation
01	INVALID COMMAND	Unrecognized command
02	BAD COMMAND FORM	Tried to use query/set command as toggle command.
03	BAD CHAR PAST COMMAND	Invalid character detected beyond command name.
04	BAD START COMMAND CHAR	Command line began with an invalid character (not the configured start character).
05	BAD COMMAND ARG	Value or format of a command argument is invalid.
06	SERIAL ADAPTER IS OFFLINE	The Power Center has not yet recognized the Serial Adapter as an RS remote device.
07	CTRL OPERATION FAILED	Toggle operation failed due to unspecified cause.
08	SETPT OPERATION FAILED	The Power Center did not accept the requested setpoint change.
09	485 PROTOCOL ERROR	An unexpected EIA-485 message sequence occurred.
10	485 POLL TIME-OUT	The Power Center failed to poll the Serial Adapter within the expected time period.
11	485 SETVALUE TIME-OUT	The Serial Adapter failed to receive an expected response from the Power Center within the allotted reply time.
12	485 GETVALUE TIME-OUT	The Serial Adapter failed to receive an expected response from the Power Center within the allotted reply time.
13	232 BFR OVERFLOW	Error code reserved, but not currently possible to report this.
14	CHECKSUM ERROR	The EPROM checksum is not valid.
15	SIO LPBK ERROR	The UART which supports the EIA-232 interface failed an internal data loopback test.
16	EEPROM R/W TEST ERROR	The EEPROM diagnostic test failed because the EEPROM data read did not match the data that was written.
17	INTERNAL ERROR	An internal software inconsistency has been detected.
18	VALUE IS UNAVAILABLE *(See Note, on next page.)	The Power Center cannot provide the value requested (usually due to operational mode).
19	SENSOR IS OPEN *(See Note on next page.)	The sensor for the requested measurement is reported as open by the Power Center.
20	SENSOR IS SHORTED *(See Note on next page.)	The sensor for the requested measurement is reported as shorted by the Power Center.
21	AUX NOT ASSIGNED TO DIMMER	An Aux dimmer step command was attempted on an Aux that is not assigned to a dimmer.
22	AUX OFF: DIMMER CTL IGNORED	An Aux dimmer step command was attempted on an Aux that has a dimmer assigned but is currently OFF.
23	OPTION SWITCH NOT SET	The requested function is not valid unless the appropriate Power Center option switch is configured.
24	OPTION SWITCH IS SET	The requested function is not valid because of a conflicting Power Center option switch setting.
25	FUNCTION IS LOCKED OUT	The requested function is currently locked out by the Power Center.

26	PUMP HIGH NOT ON	Pump Low cannot be activated unless the pump is currently on HIGH.
27	NOT WHEN SPILLOVER ACTIVE	Cleaner cannot be used when spa spillover (waterfall) is active.
28	NOT WHEN FREEZE IS ON	Spa or Cleaner cannot be used when freeze protect is active.
29	NOT WHEN SPA IS ON	Cleaner cannot be used when spa is active, or pump cannot be turned off while the spa is active.
30	SERVICE MODE IS ACTIVE	Control and device status query functions cannot be performed when Service mode is active.
31	TIMEOUT MODE IS ACTIVE	Control and device status query functions cannot be performed when Time-out mode is active.
99	UNEXPECTED CMD STATUS = <i>value</i>	The attempted operation failed with an unknown command status code = <i>value</i> . This is generally caused by using a Serial Adapter firmware version that is not up-to-date (compatible) with the Power Center firmware.

Table 11: Serial Adapter Error Codes

* Note: A name appears before “VALUE” for these error texts, for firmware versions later than A12 (e.g. BO1).

Name = POOL TEMP, AIR TEMP, SPA TEMP or SOLAR TEMP.

Example: ?18 POOL TEMP IS UNAVAILABLE (could be due to the pump being off).

4.4 Using an External Modem with the RS Serial Adapter

The Rev B or higher Serial Adapter hardware supports attachment of a standard external modem to the EIA-232 port using an off-the-shelf cable and a common gender adapter.

A standard “PC Modem Adapter” cable, Digikey part number AE1031-ND, can be used in conjunction with a DB9 male-to-male gender changer to connect the Serial Adapter to a standard external modem.

The male-to-male gender adapter is first plugged into the end of the Serial Adapter EIA-232 cable. Then the PC Modem adapter cable is connected between the gender adapter and the external modem.

PCB Jumper Settings

Before using a modem with the Serial Adapter, the jumpers shown in Table 12 must be configured. Jumper headers JP1 through JP4 are accessible via the bottom access hatch, however the bottom cover of the Serial Adapter must be removed to gain access to jumpers headers JP5 through JP7. Headers JP5, JP6, and JP7 are located near J1.

Recommended settings are shown for using the Serial Adapter with and without an external modem connected. The factory default jumper positions are the “No Modem” settings.

Only one of the four jumpers JP1 through JP4 should be shorted at a time.

Jumper	Modem	No Modem (default)	Explanation of jumper settings
JP1 “DCD”	Shorted	Open	If shorted, causes inactive Carrier Detect signal to hold the Serial Adapter in a reset condition. If so configured, the Serial Adapter “wakes up” only when the external modem detects a carrier from an incoming call.
JP2 “DTR”	Open	Open	If shorted, enables “reset when DTR inactive” feature.
JP3 “RTS”	Open	Open	If shorted, enables “reset when RTS inactive” feature.
JP4 “NONE”	Open	Shorted	If shorted, disables CPU EIA-232 reset options.
JP5 “DCD”	Shorted	Open	If shorted, connects Carrier Detect (DCD) signal from modem
JP6 “RI”	Shorted	Open	If shorted, connects Ring Indicator (RI) signal from modem.
JP7 “DTR-DSR”	Shorted	Open	If shorted, loops Modem DSR output to Modem DTR input.

Table 12: Modem Configuration Jumpers

Table 13 illustrates how EIA-232 signals are connected between an external modem and a Serial Adapter when using the modem cable and gender adapter described above. The boxes at the extreme left and right show the signals present on the RS Serial Adapter and typical external modem connectors respectively. The boxes between them represent the signal paths through the IBM Modem Adapter cable and the gender adapter. The columns labeled "I/O" indicate whether the signals are inputs or outputs for the associated device.

Signal	I/O	DB9S Pin		DB9P Pin	DB9P Pin		DB9S Pin	DB25P Pin		DB25S Pin	I/O	Signal
DCD	I	1		1	1		1	8		8	O	CD
TX	O	2		2	2		2	2		2	I	TD
RX	I	3		3	3		3	3		3	O	RD
DTR	I	4		4	4		4	6		6	O	DSR
GND	I/O	5		5	5		5	7		7	I/O	GND
DSR	N.C.	6		6	6		6	20		20	I	DTR
RTS	I	7		7	7		7	5		5	O	CTS
CTS	O	8		8	8		8	4		4	I	RTS
RI	I	9		9	9		9	22		22	O	RI
RS Serial Adapter				Gender Adapter			IBM Modem Adapter			Typical External Modem		

Table 13: External Modem Signal Connection

4.5 Command & Response summary for RS Serial Adapter

See “Definitions” list and Notes on page 44. (For details, see both Serial Adapter and AquaLink® RS manuals.) The following are arranged in 2 groups: cmds generally used only 1 time (at setup), then routinely used ones.

<i>Format</i>	<i>Function</i>	<i>Normal response example, when no error detected</i>
(CR ends)		(response in <u>format 0</u> is shown here) (CR ends)
#COSMSGS=1	Enable reporting of Changes Of State	!00 COSMSGS = 1 (to report AL changes, without polling) ⁸
#DIAG	run diagnostics on s.a. ¹ [i.e., see note #1]	!00 OK
#ECHO?	show whether cmd’s echoed on 232	!00 ECHO = 0 (if no echo from s.a. back to serial port)
#ECHO=[st]	set echo option to [st]= state (1=ON)	!00 ECHO = 1 (if echo wanted, = default way)
#MODEL?	show type of AL	!00 MODEL = 6520 (for example)
#OPTIONS?	show state of AL DIP sw	!00 OPTIONS = nn (see manual, Table 5) (nn=0 if all off)
#S1?	show state of s.a. DIP sw	!00 S1 = nn (nn = 3 if just pos’s 5 & 6 are on. ²)
#RSPFMT?	show which format for 232 responses	!00 RSPFMT = 0 (if verbose, = default)
#RSPFMT=[st]	<u>set</u> which format for 232 responses	!00 1 {if [st]=1, i.e. brief (terse) }
#RST	reset s.a.	Jandy Products RS Serial Adapter, Rev Lnn
#NRMCHR=nn	set new char for start of normal response	*00 NRMCHR = 42 (if nn=42.Can use dec.: 32 < nn < 127) ³
#UNITS?	show which units selected for Temp.	!00 UNITS = F [in rspfmt 1, “0” ↔ F, “1” ↔ C i.e. Celsius]
#VERS?	show version of software in s.a.	!00 VERS = Lnn (B01, for example)
#VERR?	[example of erroneous character sent]	?01 INVALID COMMAND (or, “?01 1” if RSPFMT = 1)

routine use (status, water movement, & aux.’s first, then commands related to temperature):

#LEDS?	show status of LED’s at AL Control Panel	!00 LEDS = 0 1 0 0 64 (rspfmt 1 ignores some LED’s!) [this ↑ example: Aux 1 on, Solar heater enabled]
#OPMODE?	show mode of AL system	!00 OPMODE =AUTO [0] (or service [1], or timeout [2])
#VBAT?	show v. of battery in AL (time retention)	!00 VBAT = nnn (nnn= V * 100) (or !00 VBAT = n LOW)
#PUMP?	show state of filter pump	!00 PUMP = [st] (st=1 if on now <u>or</u> soon, after delay)
#PUMP	toggle state of filter pump to opposite	!00 PUMP = [st] (st=0 if off)
#PUMP=[st]	set filter pump to definite on or off state	!00 PUMP = [st] (Same “set” format for others below.)

Note: **same as PUMP above, the following** Query commands become Toggle commands if “?” is deleted, and the **same set to =[st] usable**; there are exceptions to this, noted by the letter “Q” in front of the word “show” in “Function” column.

#PUMPLO?	show state of Low speed filter pump	!00 PUMPLO = [st](if Option DIP #2 in Pwr Cntr. is ON.)
#SPA?	show state of spa	!00 SPA = [st] (st=0 if on only due to “cool down”) ⁴
#WFALL?	show state of Waterfall (spa Spillover)	!00 WFALL = [st] (Depends on Opt’n DIP #3 in Pwr Cntr.)
#CLEANR?	show state of Cleaner function	!00 CLEANR=[st] (Depends on Opt’n DIP #1 in Pwr Cntr.)
#AUXn?	show state of Aux. n	!00 AUXn = [st] (Not valid if AUXn assigned by Opt’n sw.)
#AUXn+	step up a <u>dimmer on</u> Aux. n, <u>if there & on</u>	!00 AUXn = 1 75% (if was 50%. AL menu assigns dimmer)
#AUXX=[st]	set Extra Auxiliary to [state], if present	!00 AUXX = [st] (Not valid if Solar sensor is connected.)

Command & Response Summary for RS Serial Adapter (continued)

<i>Format</i>	<i>Function</i>	<i>Normal response example, when no error detected</i>
#POOLHT?	show state of Pool heater enable	!00 POOLHT = [st] (st=1 means htr is enabled, may heat)
#POOLHT2?	show state of htr enable to Temp2, if exists	!00 POOLHT2 = [st] (st=0 means htr is disabled) ⁵
#SPAHT?	show state of Spa heater enable	!00 SPAHT = [st] (if st=1,& spa=1, <u>and</u> spatmp<spasp, <u>heat</u>)
#SOLHT?	show state of Solar heater enable	!00 SOLHT = [st] (needs Temp. sensor at Solar terminals)
#POOLSP?	show Set Point [thermostat] for Pool	!00 POOLSP = nn F (if using Fahrenheit , else nn C)
#POOLSP=nn	<u>set</u> Set Point for Pool [<i>note: <u>no units</u> here!</i>]	!00 POOLSP = nn F (nn: 2 or 3 digits usable)
#POOLSP+	step Set Point up by 1 degree	!00 POOLSP = nn F (or, #POOLSP- steps it down) ⁶
#POOLSP2?	show Temp2 (lower) pool Set Point	!00 POOLSP2 = nn F (for “only” models, ≠ combo’s)
#SPASP?	show Set Point for Spa temperature	!00 SPASP = nn F (= 102 °F, if at initial setting)
#AIRTMP?	Q show temperature of air sensor	!00 AIRTMP = nn F (if °C in format 1, see nn+256)
#POOLTMP?	Q show temperature of Pool sensor	!00 POOLTMP = nn F (see “?20” not !00, if shorted)
#SPATMP?	Q show temperature of Spa sensor	!00 SPATMP = nn F (see “?18” if not available, e.g. if off)
#SOLTMP?	Q show temperature of Solar sensor	!00 SOLTMP = nn F (err code like “?01” if sensor open) ⁷

Command and Response Summary for RS Serial Adapter (continued)**Definitions for the list above:**

s.a. = Serial Adapter
 AL = AquaLink® RS system (connected to this Serial Adapter).
 L = a Letter (= A, initially)
 n = a number (1 digit, in base 10 [decimal])
 [st] = state: 1=ON, 0=OFF. Other alternatives for these:

Cmnds to s.a. may use 1, ON, Yes, T, or true (not sensitive to case);
 0, OFF, No, F, or False.
responses from s.a. always report state as 1 or 0.

Toggle = change state of device to opposite (on or off).

Note # ¹: #DIAG runs diagnostics which check s.a. and the connection to 232 port, but not the conn. to AL.
 # ²: “S1 = 11” (=8+2+1) for default settings (switches 3, 5 & 6 on) in serial adapter.
 # ³: NRMCHR is 1 of 3 cmd’s which can query or set characters used here; see manual for use of others.
 (CMDCHR for char. to start cmd string sent to s.a., ERRCHR for start of error responses.)
 # ⁴: SPA affects Filter Pump, rotation of JVA’s, spa heater, and possibly cleaner.
 For “combo” or “dual equipment” models only, not “Pool only / Spa only” ones. See manual.
 # ⁵: POOLHT2 and POOLSP2 apply only to AquaLink models called “Pool Only / Spa Only”.
 # ⁶: #POOLSP2+ or #SPASP+ (and #POOLSP2- or #SPASP-) perform same step up (or down) to whichever
 set point is present in the system, i.e. the cooler pool setting or the spa setting.
 Cannot step above built-in safety limit.
 # ⁷: Error code “?19” for early units. Cannot sense SOLTMP, or use SOLHT, if AUXX (= extra auxiliary) is
 needed.
 # ⁸: COSMSGS function was added beginning with version B00 of software in s.a. If power is interrupted after
 this function is turned on, the function may have to be re-started (command sent again). When this
 function is active, it may cause confusing responses to the #LEDS? command (use one or the other).

Data bit format: 8-N-1 (8 bit, no parity, 1 stop)
 Data rate: 9600 (default); can be changed using DIP sw “S1” (see Figure 3 in manual).
 DIP switch S1: in adapter, near J2. Typical setting: only positions 3, 5, and 6 on (see that Figure 3).
 If setting of this switch must be changed, turn **power off** first (by removing AC line
 power at AquaLink power center, if possible).

Command format: # cmd CR (default), where cmd = a command shown in list, under “Format” (“#”once);
 CR = carriage return (13 dec.).
 UPPER or lower case accepted; spaces are allowed, not required.

Initial Character: # (= 35 dec.) can be changed; e.g.: “#CMDCHR=96” makes ` = new char. (See manual.)

Delays: AquaLink® RS system has various built-in delays for safety. When one of those is active, a
 “query” command will return info. about the state which *will* be present after the delay.

Dimmers: Light dimming requires optional module, & use of AL menu to set up initially. Then,
 light can be turned on followed by adjust up (+) or down (-) through s.a. If using a
 terminal, note that (+) and (-) keys on “number pad” part of keyboard do not work on all
 computers. “Shift +=” works.

4.6 PHASTLink Serial Adapter

*Note: This adapter must be used indoors (it is not weather-resistant).

4.6.1 Description

The AquaLink RS PHASTlink Serial Adapter is an interface that allows a device in a PHAST system to connect to a Jandy AquaLink RS system for the purposes of obtaining status and performing limited control operations. (Notice that the term “PHAST system” here refers to equipment that may have come from the AMX or Panja corporations, depending on dates.)

As illustrated in Figure #5, the microprocessors within this adapter translate the commands received through the PHASTLink port into the protocol used by the AquaLink RS Power Center and its connected devices. Conversely, information from the AquaLink RS Power Center is translated into the format used within the PHAST system. The PHASTLink port is typically an 8-position RJ-45 socket that may be built into a PHAST cardframe.

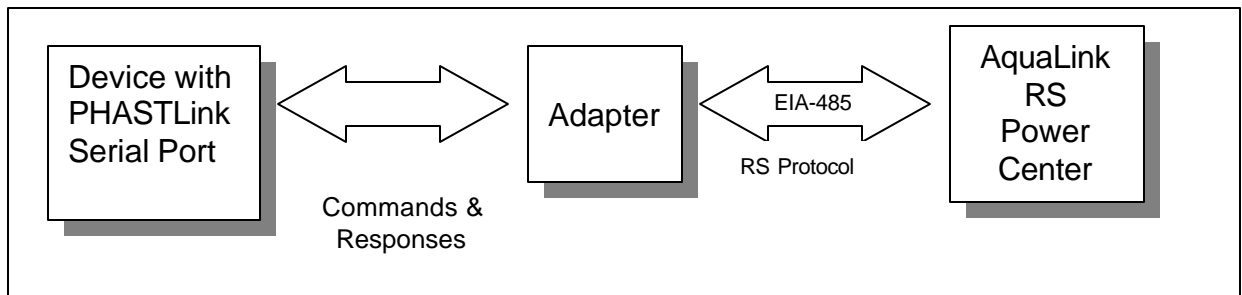

Figure 5: AquaLink RS/PHASTLink Serial Adapter Concept

Connection and programming of this adapter should be handled by a technician skilled in the PHAST system and its “Landmark” program. The adapter will not work at all without proper programming of the PHAST equipment.

4.6.2 Installation Instructions:

Operating in conjunction with a Jandy AquaLink RS control system, this adapter allows a PHAST automation system to monitor conditions at the pool/spa site. The automation system will also be able to command changes of most pool/spa functions (such as turn on pumps, turn valves, switch the heater or auxiliaries, and change thermostat settings). Note that the main AquaLink system will continue to be usable to override the automation system, and its control panel will be needed for entering or altering the setup or internal programs stored there. Refer to the AquaLink RS Owners Manual.

The AquaLink RS control system must have appropriate firmware installed; revisions marked Rev.HH-232 or I (or later) can communicate through the adapter.

This may be verified with the installer, or by inspecting the label on the PPD (“U2”) in the power center, or by pressing and releasing the switch mounted behind the small hole on the

side of the AquaLink control panel (first rev. displayed there will be that of the control panel's firmware, the second will be the power center's which is the important one). If Rev. "HH" or older appears, contact Tech. Service at 707-776-8200, ext.260.

Wiring PHASTLink serial port to the adapter:

Follow standard practice for this connection, as called for by PHAST (or AMX or Panja technicians).

Wiring Jandy AquaLink[®] RS control system to the adapter:

Power: Be sure that power to the AquaLink[®] RS control system is off when making the connection to this adapter. (But don't leave it off for hours, or the battery in the AquaLink will run down; that would cause loss of time & date settings.)

Run 4-wire cable (22 AWG or heavier is recommended) between a device in the AquaLink system and the adapter. That device is typically the indoor control panel, but another may be chosen as long as it is connected using one of the red 4-position terminal bars. Note the wire color codes; these Jandy devices use this standard pattern (see Table 1).

The wires coming from the Serial Adapter may be "doubled up" on the red terminal bar with the four wires coming from the Power Center (see Figure 4). To avoid installing more than two wires in each terminal, order and use a Jandy Multiplex PCB Kit, which includes the Multiplex Board (part #6584). Never put more than two wires into each of the pins of the terminal bar.

Lightning: If the run to the AquaLink RS system is long, and it is in an area prone to lightning storms, a Surge Protection board (part #6585) is recommended.

Power LED's: Two should light, indicating receipt of power from PHASTLink (LED on end) and from AquaLink (mid-label).

Commands and Protocol:

The majority of this manual describes the functions, commands, and responses used with the serial adapter. For use with a PHAST system, some of the commands are unnecessary and are not accessible by most users of the Landmark program; examples are most of the "Configuration" commands, which are listed first under the heading "Command Descriptions" in this manual (refer to the Table of Contents). Commands described after those configuration-related ones are the groups of commands related to pumps, valves, and temperatures. Those can all apply to systems controlled by PHAST, and those sections should be read. The difference is simply in the way they are entered: PHAST users can ignore the typing details (like the "#" signs, spelling, carriage returns, and so forth). The same functions are entered by the graphical process familiar to users of that system.

"P3" Icon:

The set of commands used with the Jandy AquaLink RS system is accessible using PHAST's "Landmark" program, through a toolbar icon in the "P3 Accessories" group (under the "Design" tab).

NOTES

NOTES



*6000 Condor Drive, Moorpark, CA, USA 93021 • 707.776.8200 FAX 707.763.7785
480 S. Service Road West, Oakville, Ontario, Canada L6K 2H4 • 905.844.8233 FAX 905.844.2635

Litho in U.S.A. © Water Pik Technologies, Inc. 0502