

INSTALLATION and OWNER'S INSTRUCTIONS



Pool Control
BY
JANDY

Important Safety Precautions

When installing and using this electrical equipment, basic safety precautions should always be followed, including the following:

- 1. READ AND FOLLOW ALL INSTRUCTIONS.**
LIRE LA NOTICE TECHNIQUE.
- 2. DANGER** - to reduce the risk of injury, do not permit children to use this product unless they are closely supervised at all times.
- All electrical work must be performed by a licensed electrician and must conform to all national, state, and local codes.
WARNING: Water temperature in excess of 100°F/38°C may be injurious to your health.
AVERTISSEMENT: Il peut être dangereux pour la santé de se plonger dans de l'eau à plus de 38°C/100°F.
- Prolonged immersion in hot water may induce hyperthermia. Hyperthermia occurs when the internal temperature of the body reaches a level several degrees above the normal body temperature of 98.6° F. The symptoms of hyperthermia include dizziness, fainting, drowsiness, lethargy, and an increase in the internal temperature of the body. The effects of hyperthermia include: 1) unawareness of impending danger; 2) failure to perceive heat; 3) failure to recognize the need to exit spa; 4) physical inability to exit spa; 5) fetal damage in pregnant women; 6) unconsciousness resulting in a danger of drowning. **WARNING - The use of alcohol, drugs, or medication can greatly increase the risk of fatal hyperthermia in hot tubs and spas. AVERTISSEMENT: La consommation d'alcool ou de drogue augmente considérablement les risques d'hyperthermie mortelle dans une cuve de relaxation.**
- Install to provide drainage of compartment for electrical components.
- Install at least five (5) feet from the inside wall of the pool and tub.
Canadian installations must be at least three (3) meters from the water.
Les installations canadiennes doivent se trouver à au moins trois (3) mètres de l'eau.
- A ground-fault circuit-interrupter must be provided if this device is used to control underwater lighting fixtures. The conductors on the load side of the ground-fault circuit-interrupter shall not occupy conduit, boxes or enclosures containing other conductors unless the additional conductors are also protected by a ground-fault circuit-interrupter. Refer to local codes for complete details.
- A terminal bar marked GROUND is provided within the Power Center. To reduce the risk of electrical shock, connect this terminal bar to the grounding terminal of your electric service or supply panel with a continuous green insulated copper wire equivalent in size to the circuit conductors supplying this equipment, but no smaller than No. 12 AWG (3.3 mm²). In addition, a second wire connector should be bonded with a No. 8 AWG (4.115 mm) copper wire to any metal ladders, water pipes, or other metal within 5 feet (1.52 m) of the tub.
- CONTROL SYSTEM IS INTENDED TO CONTROL HEATERS WITH BUILT-IN HIGH LIMIT CIRCUITS ONLY.**
- PLEASE SAVE THESE INSTRUCTIONS.**

SPECIFICATIONS:

POWER SUPPLY: 120 Volts A.C.; 60 Hz.; 3 amps.

CONTACT RATING: (High Volt.) 25 amp; 3 h.p. @ 240 Volts A.C., 1½ h.p. @ 120 Volts A.C.; 1500 Watts Incandescent

CONTACT RATING: (Low Volt.) Class Two, 1 amp at 24 Volts A.C.

DIMENSIONS:

Standard Power Center: Height - 13 3/4"; Width - 14 1/2"; Depth - 5".

Sub Panel Power Center: Height - 20"; Width - 14½"; Depth - 5".

Pool Control Switch Plate: Height - 5 1/2"; Width - 5 1/2"; Depth - 3/8".

CONTENTS:

- Control Panel with four Rocker Switches (weather resistant)
- Power Center with 24-hour Time Clock - 120 Volts AC

Table of Contents

1	Safety Precautions <i>Safety Precautions</i> <i>Specifications</i>
2	Table of Contents
3	Basic Installation
4	Installation of Optional Equipment
5	Back View of Circuit Board Functions of Power Center Switches
6	Gasket Seal Installation
7	Heater Wiring Guidelines
8-9	Pool Control Owner's Instructions
10	Pool Control Wiring Diagram

Basic Installation

BASIC INSTALLATION: (Read instructions completely before beginning installation.)

1. **BE SURE THAT POWER IS TURNED OFF BEFORE WIRING POWER CENTER.**
2. Remove Power Center and brackets from the shipping box. Mount brackets to the back of the Power Center. Secure Power Center to a sturdy surface.
3. Determine the best location for the Pool Control (switch plate) and mount a double gang box (not included) at this location. If the Pool Control switch plate will be installed outdoors, use a weather-tight double gang box. Seal all unused openings at the top and sides of the weather-tight box with silicone sealer and provide a small drain hole (1/8") at the bottom.
4. Run electrical conduit with sweep elbows between the Power Center and the double gang box.
5. Open the Power Center door; unscrew and remove both the faceplate and the Low Voltage Panel which the faceplate covers. The orange transformer connector should already be on "J1" (3-pin). The time clock should already be wired and its switch (not its motor) should be connected to the "F. PUMP" socket (SK1) on the underside of the circuit board.
6. Run 8-conductor wire through conduit between Pool Control switch plate and Power Center. This wire runs through the Low Voltage raceway on left side of Power Center. (See Pool Control Wiring Diagram on Page 10.) Do not run high voltage (line power) wires in this raceway.
7. Strip the 8-conductor wires no more than 3/8", noticing that the Green/Black wire should be skipped, as it is not used for this model. Follow Wiring Diagram to connect these wires to terminals 1 through 11 (skip terminals 2, 5, 8, 9, and 14).
8. **HEATER WIRING CONNECTIONS:**

Thermostat: Connect two 18 AWG wires rated for 105 degrees C in series with the heater's thermostat. Turn the heater's thermostat to desired water temperature and set the selector switch to **ON**. (See **Fig. 3 - Gas Heater Connection** on Page 7, or see "Electric Heater socket" paragraph on Page 4.)
9. **JVA 2440** - Mount JVA on cleaner valve (if applicable) and feed wire through low voltage raceway to the circuit board. Plug in cord according to Wiring Diagram.
10. Wire the filter pump and other high voltage equipment to the relay contacts as shown in the Wiring Diagram on Page 10 for the Aux 1 Relay (Line, Load for 120 VAC - Line 1, Load 1, Line 2, Load 2 for 220 VAC). Plug relay coil wires into appropriate relay sockets. For example, plug the coil wires connected to the relay controlling the filter pump into the F. PUMP socket. Connect equipment grounds, and wire system power to 120 VAC.
11. **Pool Control Connection** - Go to the double gang box location, strip each of the 7 wires and using wire nuts, connect them to the rocker switches per the Wiring Diagram on Page 10. Install the Pool Control switch plate with the gasket seal (see gasket seal installation instructions on Page 6) into double gang box. Do not put on decal until testing has been completed.
12. Close panel, turn on power and test system, including rocker switches at the Pool Control switch plate. Set the time clock(s) by rotating clocks clockwise only.

Installation of Optional Equipment

INSTRUCTIONS FOR INSTALLING OPTIONAL OR UNCOMMON EQUIPMENT:

- *To install a second time clock (Part Number 7152):*

A second time clock can control the pool cleaner pump, pool cleaner JVA or either of the auxiliary circuits. If a second time clock is installed, plug its switching wires into the appropriate socket, according to the desired function (marked on the circuit board) (see **Fig. 1 - Back View of Circuit Board**, Page 6).
- *Electric Heater socket and TB2 (for use with a high voltage electric heater or heat pump):*

(See **Fig. 1 - Back View of Circuit Board**, Page 6.) The Electric Heater socket and TB2 are used if a high voltage electric heater or heat pump with a 120 VAC thermostat is installed, or if the heater is a millivolt type and the distance to the switch plate (control) is 10 feet or more. If so, plug the coil wires for the relay which will drive that heater into this socket. Connect the two wires from the HEATER switch (middle and upper terminals) on the Pool Control switch plate to TB2; do this instead of using the HEATER switch wiring shown on the Wiring Diagram on Page 11. In this case, TB1 pins 9 through 14 will have no wires connected to them.
- *Heater Cool Down Option (JP1):*

Normally, the filter pump is kept running for about 5 minutes, after the filter pump switch is turned off, or after the filter pump time clock turns off. This allows the heater to cool down safely. If this is not needed (for use with heat pumps or electric heaters which do not retain residual heat), move the slide-on jumper to pins 1 and 2 of JP1; in that position, the filter pump turns off immediately. JP1 is located on the back side of the circuit board, near the corner by the Electric Heater socket (see **Fig. 1 - Back View of Circuit Board**, Page 6).
- *Freeze Protection (Part Number 7026):*

Mount the Freeze Sensor in the Low Voltage raceway, as per instructions included in Freeze Sensor Kit, Part No. 7026. Without letting the capillary tube of the Freeze Sensor kink or bend, carefully uncoil and extend it outside through the knockout hole at the bottom of Power Center. Connect Freeze Sensor switch to terminals 7 and 8 on TB1 (see **Pool Control Wiring Diagram** on Page 11 for location of TB1).

NOTE: To allow the pool cleaner to operate less time than the filter pump, you will need to install a second time clock, Part No. 7152, and a relay, Part No. 6581. Remove the jumper between pins 5 and 8 on the TB1 if a cleaner time clock is installed.

Back View of Circuit Board

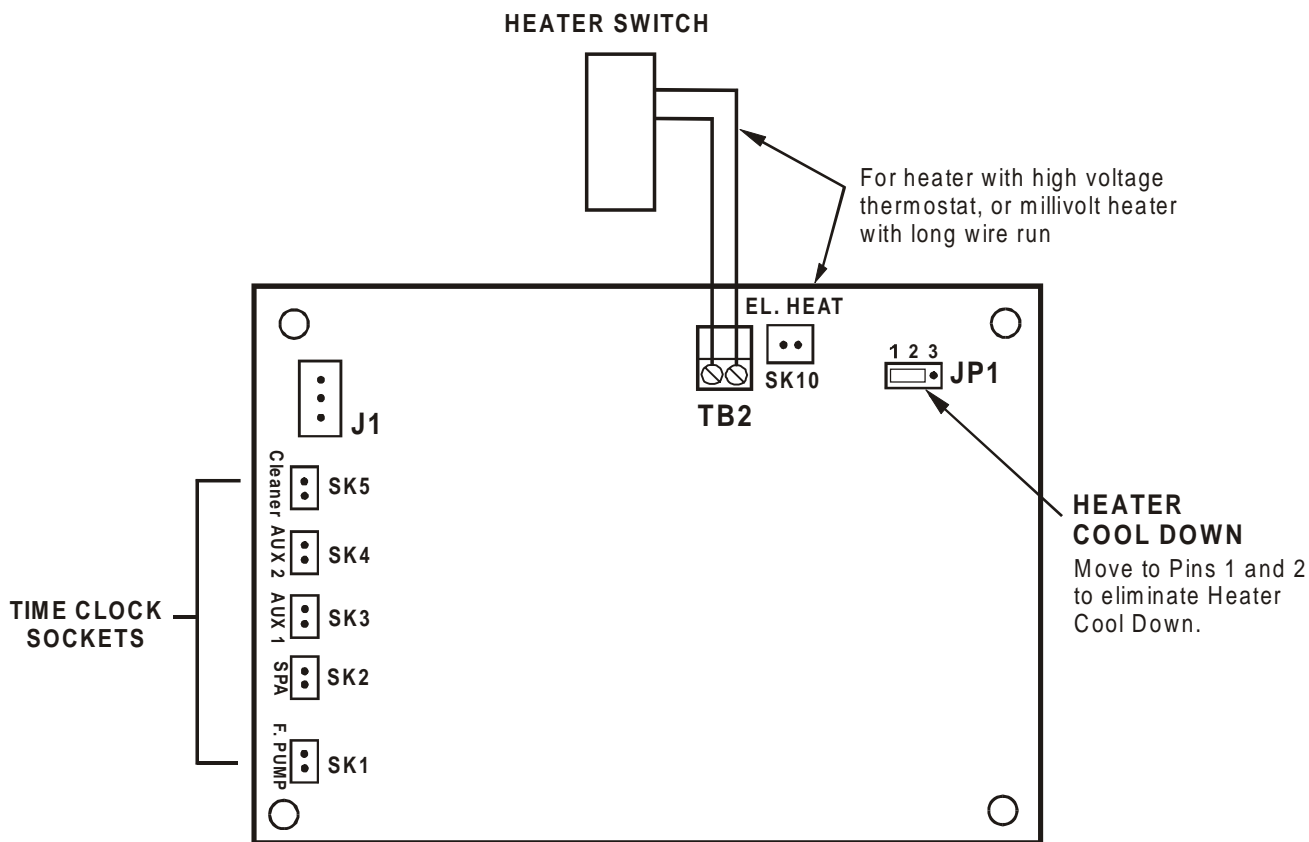

Figure 1. Back View of Circuit Board

FUNCTIONS OF POWER CENTER SWITCHES:

FILTER PUMP Switch -

- AUTO** Allows normal control of the pump by the time clock, and by a user at the Pool Control panel.
- OFF** Keeps the filter pump off. This means the pump cannot be turned on by the Filter Pump switch at the Control Panel, by the time clock, the cleaner selection, **or even by the Freeze Sensor**. Switching to this **OFF** position also interrupts the Heater Cool Down function, if that is currently keeping the pump on.
- MANUAL** Turns the pump on directly.

NOTE: The heater cannot be turned on from this Power Center switch. The time clock must be engaged in order to heat the pool using the Power Center switches.

VALVES Switch - This switch applies only to the AquaSwitch Pool and Spa system, *not the Pool Control system.*

Gasket Seal Installation

Installing the Gasket Seal Inside the Pool Control Switch Plate

If mounting Pool Control switch plate indoors, place the black gasket seal inside the switch plate (with cutout for LED facing towards top of unit) before securing switch plate to wall. After switch plate has been attached to the wall with four screws, tear off outer perforated edge of gasket seal extending outside the switch plate.

If the unit is to be installed outdoors, place the gasket seal inside the switch plate and tear off excess material at inner perforation. Be sure cutouts for the drain holes are located at the bottom of switch plate and LED cutout is at the top. Turn the switch plate over and attach to outlet box with four screws.

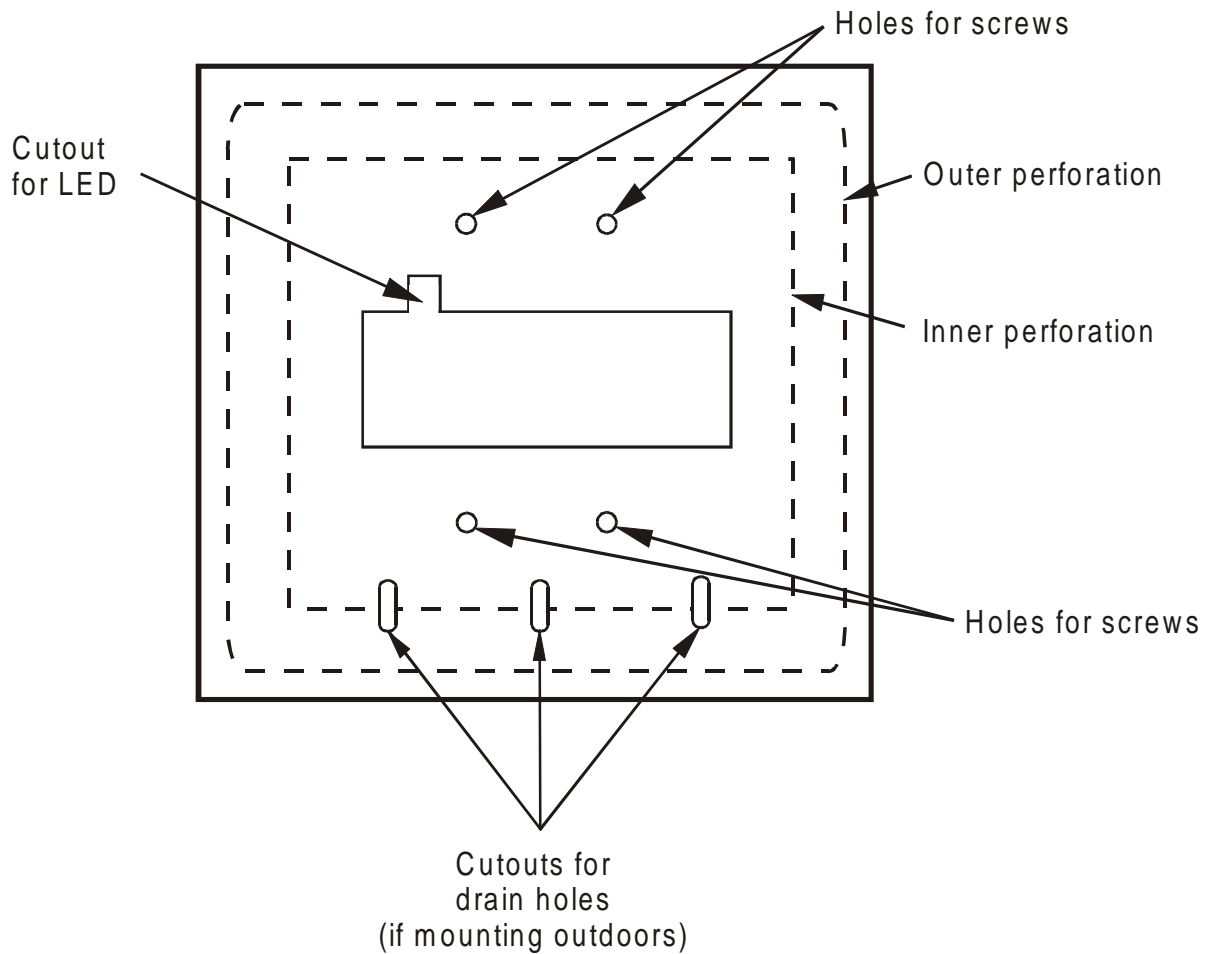

Figure 2. Gasket Seal for Switch Plate

Heater Wiring Guidelines

GENERAL HEATER WIRING GUIDELINES

Electric Heaters and Heat Pumps

The instructions on this page are for low voltage heaters. DO NOT attempt to connect a heater with a high voltage (110 or 220 VAC) thermostat into the low voltage heater terminal bar (See Page 4 for installing with high voltage heaters).

GAS HEATER CONNECTION (Millivolt or electronic ignition)

At the Heater:

Connect two 18 AWG wires in series with the heater circuitry as if you were wiring a Fireman's Switch or heater delay. DO NOT disconnect or bypass the pressure or limit switches.

Place the heater toggle switch in the **ON** position and set the thermostat to the desired temperature.

At the Power Center:

For an **electronic ignition** heater (which uses Low voltage AC power), connect the two wires from the heater to terminals 12 and 13 of the 14-pin terminal bar.

For a **millivolt** heater (which is not AC-powered), estimate the length of the wire run from the Control Panel to the Power Center. If the distance is short (less than about 10 feet), connect as above (to terminals 12 and 13). For longer runs, use of an additional relay can avoid problems due to voltage drop along the wire run. Connect as for an Electric (high voltage) heater; see pages 4 and 5.

NOTE: Some heaters require a remote wiring harness; check with the heater manufacturer to determine if this is needed.

24 VAC Thermostat Circuit
(See Pages 4 & 5 for
110 VAC thermostat
or millivolt)

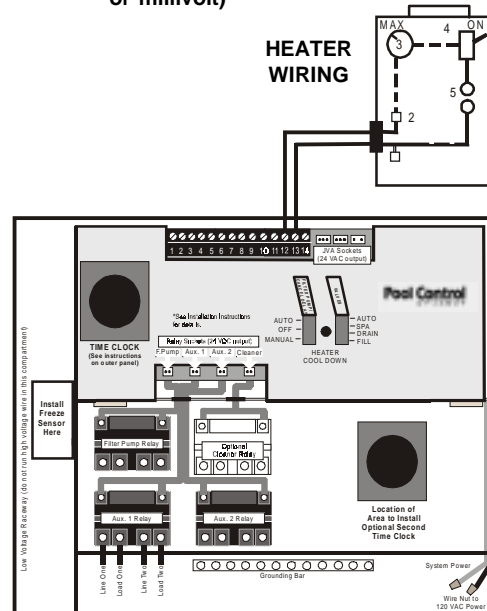

Figure 3. Single Thermostat Heater Connection

Pool Control Owner's Instructions

The four rocker switches on the Pool Control switch plate are used to control your filter pump and three auxiliary functions you have selected to have installed, such as a pool heater, lights, fountains or fiber optics.

A 24-hour time clock regulates filtration to keep your pool clean.

Operation from the Pool Control switch plate

(The two switches back at the Power Center must be in the "AUTO" (up) position to operate the Pool Control normally.)

FILTER PUMP SWITCH

The filter pump switch will override the time clock and start circulation throughout the pool.

NOTE: The Pool Control is equipped with a heater cool down delay. The filter pump will run for approximately 5 minutes after it has been deactivated from either the time clock or filter pump switch, unless the installer has disabled this cool down function.

HEATER SWITCH

To activate heater, press the heater switch to ON. If the time clock has not turned on the pump, move the filter pump switch to ON.

CAUTION: Remember to turn off the heater switch when you have finished heating the pool. Failure to do so will cause the heater to run during the regular time clock cycle.

AUX 1 AND AUX 2 SWITCHES

The **ON** (up) position turns on any auxiliary equipment (pool light, waterfall, etc.). Check with the installer of the equipment to determine what is on the circuit.

NOTE: The installer may select an auxiliary switch on the control panel to operate the pool cleaner. When engaged, the Pool Control will automatically turn on the filter pump and pool cleaner. The pool cleaner can also be engaged from the filter pump time clock or from a second time clock, depending on the installation.

Operation from the Power Center

TIME CLOCK

- | | |
|------------|--|
| Large dial | Sets the regular on/off cycle for the pump. See directions printed on the Power Center panel. (Turn this dial clockwise only). |
| Small dial | This is an override knob, which can be used to start and stop the pump regardless of the time. Regular cycle will resume the next period (a period is 1/2 hour) following any turning of this knob. (Turn this knob counterclockwise.) |

(continued)

Pool Control Owner's Instructions

FILTER PUMP SWITCH

AUTO Allows normal control by the time clock, or by a user at the Pool Control switch plate.

OFF Keeps the pump off. This means the pump cannot be turned on by the Filter Pump switch, time clock, cleaner selection, **or even by the Freeze Sensor**. Switching to this OFF position also stops the heater cool down function, if that function is currently keeping the pump on.

MANUAL Turns on the filter pump directly. This position will not allow the heater to fire.

VALVES SWITCH

This switch applies only to the AquaSwitch Pool and Spa system; it is not used for the Pool Control.

L.E.D.

The light emitting diode (L.E.D.) will flash during the cool down cycle.

For normal operation, both switches should be left in the AUTO position.



Pool Control Wiring Diagram

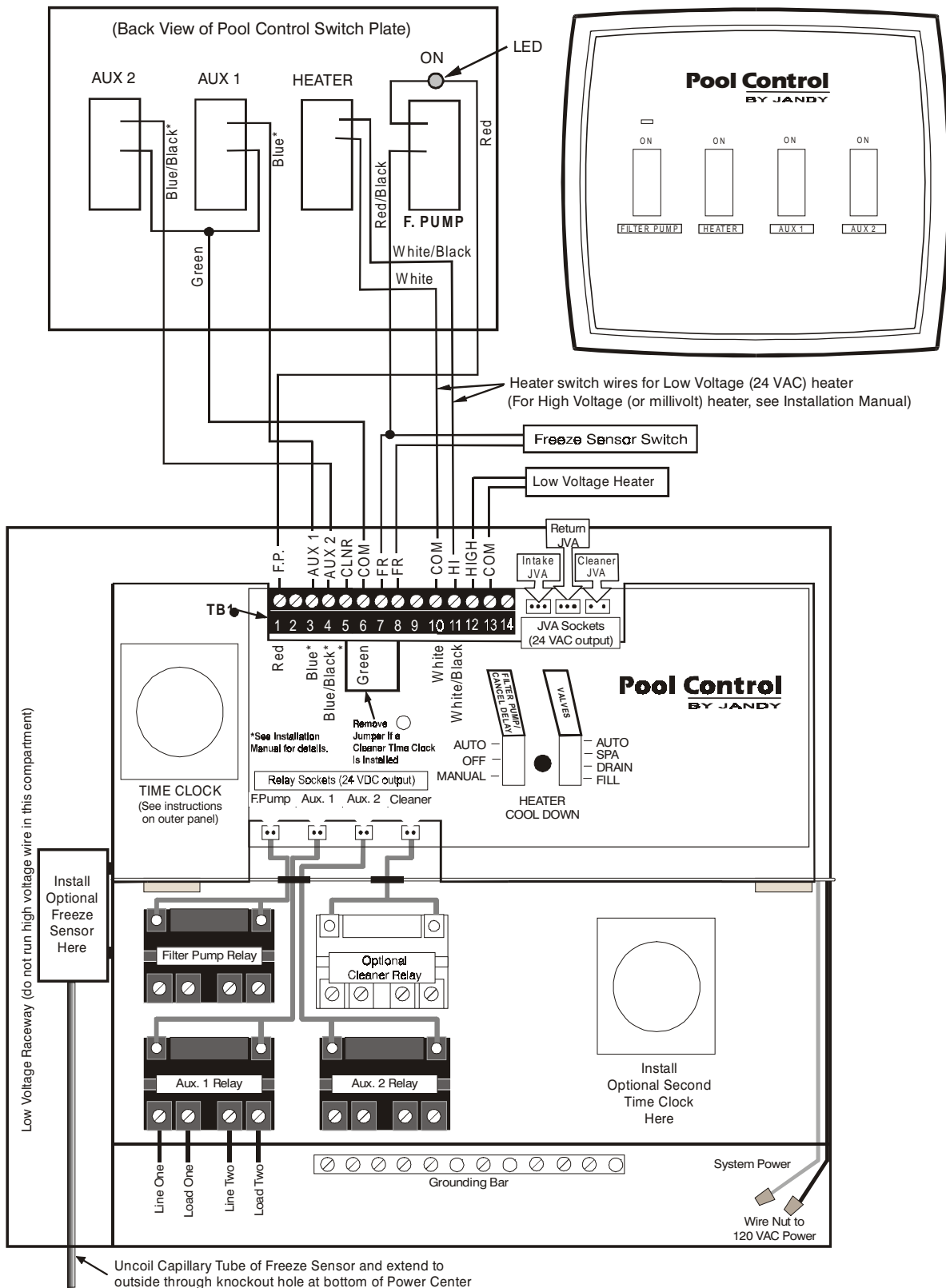

LIMITED WARRANTY

Thank you for purchasing Jandy® pool and spa products. Waterpik Technologies (manufacturer of Jandy products, including Laars® pool and spa heaters) warrants all parts to be free from manufacturing defects in materials and workmanship for a period of one year from the date of retail purchase, with the following exceptions:

- AquaLink® RS units installed with Jandy Surge Protection Kits will be covered for two years.
- NeverLube® valves are warranted for the life of pool and/or spa on which they were originally installed.

This warranty is limited to the first retail purchaser, is not transferable, and does not apply to products that have been moved from their original installation sites. The liability of Waterpik Technologies shall not exceed the repair or replacement of defective parts and does not include any costs for labor to remove and reinstall the defective part, transportation to or from the factory, and any other materials required to make the repair. This warranty does not cover failures or malfunctions resulting from the following:

1. Failure to properly install, operate or maintain the product(s) in accordance with our published Installation, Operation and Maintenance Manuals provided with the product(s).
2. The workmanship of any installer of the product(s).
3. Not maintaining a proper chemical balance in your pool and/or spa [pH level between 7.2 and 7.8, Total Alkalinity (TA) between 80 to 120 ppm, Total Dissolved Solids (TDS) less than 2000].
4. Abuse, alteration, accident, fire, flood, lightning, rodents, insects, negligence or acts of God.
5. Scaling, freezing, or other conditions causing inadequate water circulation.
6. Operating the product(s) at water flow rates outside the published minimum and maximum specifications.
7. Use of non-factory authorized parts or accessories in conjunction with the product(s).
8. Chemical contamination of combustion air or improper use of sanitizing chemicals, such as introducing sanitizing chemicals upstream of the heater and cleaner hose or through the skimmer.
9. Overheating, incorrect wire runs; improper electrical supply; collateral damage caused by failure of O-Rings, DE grids, or cartridge elements; or damage caused by running the pump with insufficient quantities of water.

LIMITATION OF LIABILITY:

This is the only warranty given by Waterpik Technologies. No one is authorized to make any other warranties on Waterpik Technologies' behalf. **THIS WARRANTY IS IN LIEU OF ALL OTHER WARRANTIES, EXPRESSED OR IMPLIED, INCLUDING BUT NOT LIMITED TO ANY IMPLIED WARRANTIES OF FITNESS FOR A PARTICULAR PURPOSE AND MERCHANTABILITY. WATERPIK TECHNOLOGIES EXPRESSLY DISCLAIMS AND EXCLUDES ANY LIABILITY FOR CONSEQUENTIAL, INCIDENTAL, INDIRECT OR PUNITIVE DAMAGES FOR BREACH OF ANY EXPRESSED OR IMPLIED WARRANTY.** This warranty gives you specific legal rights. You may also have other rights which vary by state or province.

WARRANTY CLAIMS:

For prompt warranty consideration, contact your dealer and provide the following information: proof of purchase, model number, serial number and date of installation. The installer will contact the factory for instructions regarding the claim and to determine the location of the nearest designated service center. If the dealer is not available, you can locate a service center in your area by visiting www.jandy.com or by calling our technical support department at (707) 776-8200 extension 260. All returned parts must have a Returned Material Authorization number to be evaluated under the terms of this warranty.



A Waterpik Technologies Company
6000 Condor Drive • Moorpark, CA USA 93021 • 707.776.8200 • Fax 707.763.7785
480 S. Service Road West • Oakville, Ontario, Canada L6K 2H4 • 905.844.8233 • Fax 905.844.2635

Litho in USA ©Waterpik Technologies 0407